

ENVIRONMENTAL MANAGEMENT PROGRAMME (EMPr)

for the management of activities relating to the protection of the natural environment during the construction
and operation phases

PART 2 AMENDMENT APPLICATION OF THE VANRHYNSDORP SOLAR PHOTOVOLTAIC (PV) FACILITY ON PORTION 7 OF THE REMAINDER OF THE FARM DE DUINEN NO. 258 NEAR VANRHYNSDORP WITHIN THE MATZIKAMA LOCAL MUNICIPALITY IN THE WESTERN CAPE PROVINCE

JULY 2023

Compiled by:

EnviroAfrica cc

D:FFE EA reference number: 14/12/16/3/3/1/1854/AM2

**PART 2 AMENDMENT APPLICATION OF THE
VANRHYNSDORP SOLAR PHOTOVOLTAIC (PV) FACILITY ON
PORTION 7 OF THE REMAINDER OF THE FARM DE DUINEN
NO. 258 NEAR VANRHYNSDORP WITHIN THE MATZIKAMA
LOCAL MUNICIPALITY IN THE WESTERN CAPE
PROVINCE
DECLARATION OF UNDERSTANDING**

I _____

Representing: _____

Declare that the conditions of the EMP were brought to my attention and that I have read and understood the contents of this Environmental Management Plan as prepared by EnviroAfrica, of which a copy has been made available to me.

Site: _____

Date: _____

I also declare that I understand my responsibility in terms of enforcing and implementing the Environmental Specifications as set out in this Environmental Management Programme.

I also undertake to inform all persons under my supervision of these specifications and the contents of the Environmental Management Programme.

Signed: _____

Place: _____

Date: _____

Witness 1: _____

TABLE OF CONTENTS

DECLARATION OF UNDERSTANDING	ii
1. INTRODUCTION	1
1.1 PURPOSE	2
1.2 SCOPE.....	2
1.3 SITE LOCATION.....	2
1.4 PROJECT DESCRIPTION	3
1.4.1 Access.....	5
1.5 THE RECEIVING ENVIRONMENT.....	6
1.5.1 Vegetation types expected.....	6
1.5.2 Surface Water	6
1.5.3 Archaeological, heritage and palaeontological resources	7
1.5.4 Animals and avifauna species	7
1.6 RECOMMENDATIONS ON IMPACT MITIGATION/MINIMISATION	7
1.7 ENVIRONMENTAL AUTHORISATION	17
2. DEFINITIONS AND ABBREVIATIONS:.....	18
2.1 DEFINITIONS.....	18
2.2 ABBREVIATIONS	20
3. CONSTRUCTION PHASE EMP	21
3.1 STRUCTURE AND RESPONSIBILITY	21
3.1.1 The client / applicant / owner	21
3.1.2 The Construction Supervisor	21
3.1.3 The contractor.....	21
3.1.4 The Environmental Control Officer (ECO).....	22
3.1.5 Health & safety officer:	23
3.2 COMMENCEMENT OF WORKS	24
3.3 ISSUES OF CONCERN.....	24
3.4 SITE SPECIFIC ARRANGEMENTS & CONSTRUCTION PROCEDURES	25
3.4.1 On-site start-up meeting.....	25
3.4.2 Start-up meeting participants.....	25
3.5 ENVIRONMENTAL- & AWARENESS TRAINING	26
3.5.1 Environmental awareness course	26
3.5.2 Specific training.....	26
3.6 METHOD STATEMENTS	26
3.6.1 Additional method statements	27
3.7 NON-COMPLIANCE.....	28
3.7.1 Corrective action instruction.....	28
3.7.2 Written warning.....	28

3.7.3	<i>Penalty fines</i>	28
3.7.4	<i>Stop works</i>	28
3.8	CHANGES TO EMP.....	29
3.9	RECORD KEEPING.....	29
3.10	STANDARD MANAGEMENT PROCEDURES.....	29
3.10.1	<i>Access & haul routes</i>	29
3.10.2	<i>Appropriate use of machinery</i>	30
3.10.3	<i>“No-Go” areas</i>	30
3.10.4	<i>Restriction of working areas</i>	31
3.10.5	<i>Protection of natural vegetation</i>	32
3.10.6	<i>Protection of fauna and Avi-fauna</i>	32
3.10.7	<i>Clearing of vegetation, stripping & conservation of topsoil</i>	32
3.10.8	<i>Erosion & sedimentation control</i>	33
3.10.9	<i>Alien invasive management plan</i>	34
3.10.10	<i>Protection of archaeological & paleontological remains</i>	35
3.10.11	<i>Storage of construction material & stockpiling</i>	37
3.10.12	<i>Oil storage and management</i>	38
3.10.13	<i>Storing of petroleum products</i>	38
3.10.14	<i>Storing of hazardous substances</i>	39
3.10.15	<i>Use of cement or concrete</i>	39
3.10.16	<i>Fire fighting</i>	41
3.10.17	<i>Emergency Procedures</i>	41
3.10.18	<i>Solid waste management</i>	41
3.10.19	<i>Toilets & Ablution Facilities</i>	42
3.10.20	<i>Discharge of construction water</i>	42
3.10.21	<i>Eating facilities</i>	43
3.10.22	<i>Dust Control</i>	43
3.10.23	<i>Restoration and rehabilitation</i>	43
3.10.24	<i>Land Management</i>	44
3.10.25	<i>Socio-Cultural Issues</i>	44
3.11	EMERGENCY PREPAREDNESS & RESPONSE.....	45
3.11.1	<i>Accidental fires</i>	45
3.11.2	<i>Hydrocarbon spills</i>	45
3.11.3	<i>Concrete/cement spillages</i>	45
4.	OPERATIONAL EMP (OEMP)	46
4.1	TRAFFIC ACCESS ROUTES & HAUL ROADS.....	46
4.2	ENERGY MANAGEMENT.....	46
4.3	WATER MANAGEMENT.....	47
4.4	EROSION & SEDIMENT CONTROL.....	47

4.5	WASTE & POLLUTION MANAGEMENT	48
4.6	MINIMISE DUST AND AIR EMISSIONS.....	48
4.7	MANAGEMENT OF NATURAL AREAS.....	48
4.8	EMERGENCY PREPAREDNESS AND RESPONSE.....	48
4.8.1	Accidental fires.....	48
4.9	CHEMICAL MANAGEMENT	49
4.10	HYDROGEN AND BATTERY ENERGY STORAGE SYSTEM (BESS) MANAGEMENT	50
5.	ENVIRONMENTAL AUDIT PROGRAMME	51
6.	DECOMMISSIONING PHASE	52
7.	IMPACT MANAGEMENT OUTCOMES.....	53

LIST OF APPENDIXES

DECLARATION OF UNDERSTANDING

APPENDIX 1: ENVIRONMENTAL AUTHORISATION

APPENDIX 2: MAPS & DRAWINGS

APPENDIX 3: START-UP REPORT

APPENDIX 4: PENALTIES FOR NON-COMPLIANCE

APPENDIX 5: INFO ON METHOD STATEMENTS

APPENDIX 6: EXAMPLE OF METHOD STATEMENT

APPENDIX 7: CONTACTOR ENVIRONMENTAL CHECKLIST

APPENDIX 8: BASIC RULES OF CONDUCT

APPENDIX 9: ECO/ESO REPORT/CHECKLIST

APPENDIX 10: METHOD STATEMENT REGISTER

APPENDIX 11: ENVIROMENTAL INCIDENT REPORT FORM

APPENDIX 12: COMPLAINTS REGISTER FORM

1. INTRODUCTION

The main purpose of this Environmental Management Programme (EMP) is to prevent avoidable damage and/or minimise or mitigate unavoidable environmental damage associated with any construction, maintenance, or demolition work where there is a risk of environmental damage and to enhance positive benefits of the project.

The EMP forms part of the contractual obligations to which all contractors/employees involved in construction, maintenance, or demolition work must be committed. It serves as a guideline and baseline information document for the construction and operational of the proposed project and aims to comply with Section 24N of the National Environmental Management Act (Act no 107 of 1998) also known as NEMA, as well as the Environmental Impact Assessment Regulations, 2014 (Government Notice No R 326) and any additional specific information requested by any State Department, including the Department of Forestry, Fisheries and the Environment (D:FFE) for specific projects.

This EMP:

- identifies project activities that could cause environmental damage (risks) and provides a summary of actions required;
- identifies persons responsible for ensuring compliance with the EMP and provides their contact information;
- provides standard procedures to avoid and/or minimise the identified negative environmental impacts and to enhance the positive impact of the project on the environment;
- provides site and project specific rules and actions required, including a site plan/s showing:
 - areas where construction, maintenance, or demolition work may be carried out;
 - areas where any material or waste may be stored;
 - allowed access routes, parking and turning areas for construction or construction related vehicles;
- forms a written record of procedures, responsibilities, requirements and rules for Contractor/s, their staff and any other person who must comply with the EMP;
- provides a monitoring and auditing programme to track and record compliance and identify and respond to any potential or actual negative environmental impacts; and
- provides a monitoring programme to record any mitigation measures that are implemented;

The EMP is partly prescriptive (identifying specific people or organisations to undertake specific tasks, in order to ensure that impacts on the environment are minimised), but it is also an open-ended document in that information gained during the construction activities and/or monitoring of procedures on site could lead to changes in the EMP.

This EMP was compiled by Jan-Taljaard Marx who has a MSc. Degree in Botany and a B.Sc. in Conservation Ecology. He has been working as an Environmental Assessment Practitioner since 2019 and is currently employed at EnviroAfrica cc.

Qualifications:

- BSc. Conservation Ecology (2015 – 2018) and;
- MSc. Botany (2020), all from the University of Stellenbosch.

Expertise:

Jan-Taljaard Marx has over four years' experience in the environmental management field as an Environmental Assessment Practitioner and as an Environmental Control Officer, having worked on a variety of projects in the Western, Eastern and Northern Cape.

EAPASA Registration number: 2021/3289

1.1 PURPOSE

The purpose of the EMP is to give direction and guidance to all responsible parties, which are in turn expected to co-operate closely to minimise or avoid unnecessary environmental impacts or delays. The ECO will ensure compliance with the EMP (and other Environmental issues) and will visit the site on a regular basis during the construction phase, with additional visits at the professional, project-linked, discretion of the ECO or relevant authority.

This EMP binds all contractors, sub-contractors and other persons working on the site to adhere to the terms and conditions of the EMP throughout the construction activities of the project and any other construction activities associated with the construction of the upgrade of the site.

Any other Site-Specific additional activities decided and agreed upon at the “On Site Start-Up Meeting” must be included to form part of the EMP.

This EMP must be read and implemented together with the D:FFE Generic EMP for the development and expansion for overhead electricity transmission and distribution infrastructure, and the D:FFE Generic EMP for the development and expansion for substation infrastructure for the transmission and distribution of electricity.

1.2 SCOPE

This EMP addresses the construction phase (CEMP) and operational phase (OEMP) and all activities associated with the project. In addition it will deal with all the requirements of regulation 19 (4) of the EIA regulations (R. 982, 04 December 2014) as well as any additional specific information requested by the Department of Forestry, Fisheries and the Environment (D:FFE) pertaining to some developments.

Compliance to this EMP (which serves as a basis for all the phases of the project) will be monitored by the Environmental Control Officer (ECO). The Construction Engineer/Project Managers, the Contracting Agent(s) and the Client will be responsible for the implementation of this Environmental Management Plan.

1.3 SITE LOCATION

The site is located approximately 2.2 km north-east of Vanrhynsdorp and is adjacent to the N7 (Figure 1). Access to the site is via the access road from the R27.

Site co-ordinates: Approximate central point: 31°34'46.02"S, 18°44'46.91"E.

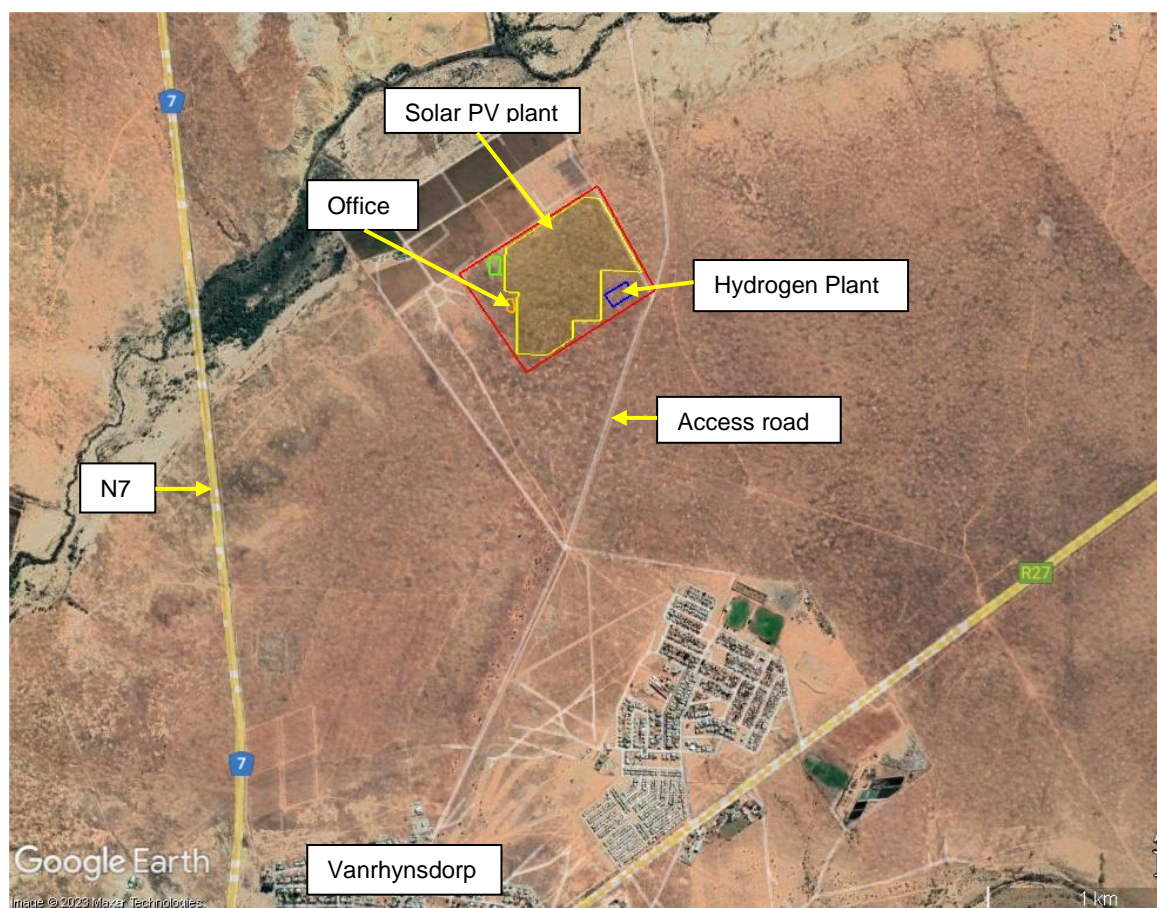

FIGURE 1: Google Earth Image showing the layout of the proposed Vanrhynsdorp solar PV facility, hydrogen plant and associated infrastructure amendment. the solar PV arrays are indicated by the yellow polygon, the hydrogen plant by the blue polygon and the offices are indicated by the orange polygon. the green polygon represents where the construction site will be.

1.4 PROJECT DESCRIPTION

Roma Energy Vanrhynsdorp (Pty) Ltd is proposing to amend the EA from 5 MW PV to 10 MW PV generation capacity and to include the development of a hydrogen plant within the assessed 20 ha on Portion 7 of the Remainder of the Farm De Duinen No. 258 near Vanrhynsdorp.

The proposed property covers an area of 278 ha, of which approximately 20 ha will be developed for the electrolysis hydrogen plant, PV array, consisting of either fixed or single axis tracking systems, and associated infrastructure, allowing for the generation of up to approximately 10 MW of alternating current.

The PV tables will be raised approximately 0.5m off the ground and will not exceed 3m in height at maximum tilt. The electrolysis hydrogen plant and associated structures will cover an area of approximately 0.8 ha within the 20 ha footprint. During the operational phase borehole water will be utilised for the electrolysis to produce hydrogen and oxygen.

Underground electrical power lines transfer generated electricity from blocks of solar panels to inverter/transformer stations within the solar panel area. From these stations, the generated power of the solar block is conveyed through underground electrical power cables to the battery energy storage system and the hydrogen plant.

The hydrogen plant has strict installation and operations protocols and standards to which it must adhere. The hydrogen plant will be installed and operated accordingly. The hydrogen plant will also be monitored at the frequency determined by the protocols / guidelines as a safety procedure and to allow for monitoring of possible leaks.

The proposed electrolysis hydrogen plant requires 5 MW to be operational. The solar facility has a maximum 10 MW peak capacity to ensure that adequate power is available for the hydrogen plant during periods of unfavourable solar conditions. The electricity generated from the maximum 10 MW peak solar facility will be used to power the hydrogen plant to split the purified water into hydrogen and oxygen. The water will be obtained from boreholes on Portion 7 of the Remainder of the Farm De Duinen No. 258 and will be stored in a reservoir as required for the electrolysis process. The proposed capacity of the reservoir is approximately 200 m³. The water use requirement for the Hydrogen Plant was indicated as 40m³/day which related to a total annual volume of 14 600m³/a.

The borehole water will be demineralized/purified prior to going through the electrolysis process (Figure 2) and the purification process is part of the electrolyser machinery that will be procured. The removed minerals will be captured and discarded in an environmentally friendly manner at a licenced facility, along with any other potential waste generated from the development.

The produced hydrogen and oxygen will typically be stored in ISO containers. A portion of the oxygen will be processed, dried and stored (bottled) for re-sale. The remainder of the oxygen will be released into the atmosphere. The hydrogen will be stored under high pressure containers with a capacity of 750 kg at 200 bar. The hydrogen facility will have a total storage capacity for dangerous goods, of approximately 25 cubic meters. The storage duration will depend on the demand, ideally the generated hydrogen and oxygen will be sold and removed from the site on a daily basis. The electrolysis hydrogen plant and its associated structures will cover an area of approximately 0.8 ha within the 20 ha footprint.

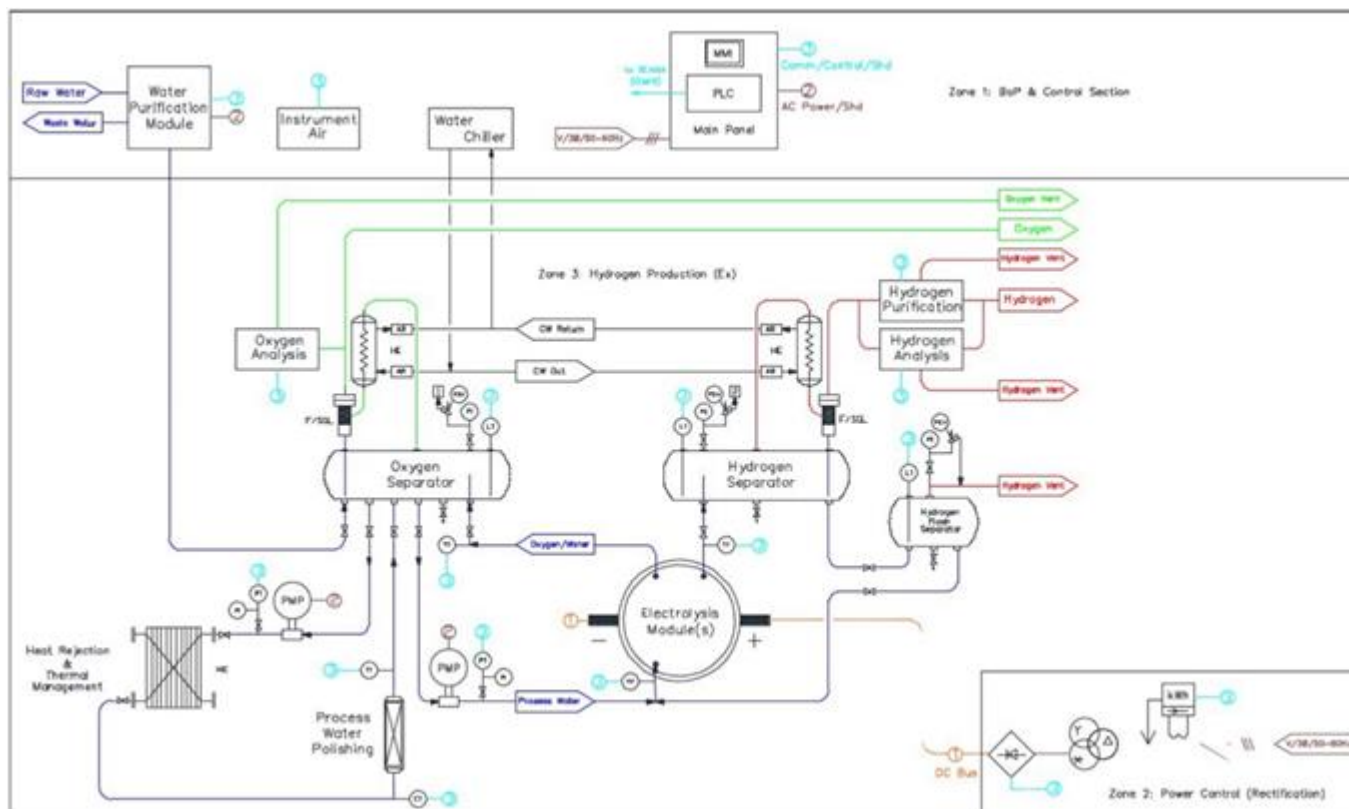

FIGURE 2: Hydrogen proton exchange membrane electrolysis simplified process flow diagram

Associated infrastructure includes the internal access roads, office buildings with ablutions, maintenance sheds, inverter-transformer stations on concrete pads, hydrogen storage containers, battery storage banks/containers, construction and operational laydown area is also included. The entire site will be fenced off.

TABLE 1: Dimensions of associated components of the solar PV facility amendment

Component	Dimensions*
Solar PV array	10 ha, 10MW
Hydrogen plant	0.8 ha
Dangerous Goods storage capacity	25 m ³

*It must be noted that these are the current estimated dimensions with current technology. Changes in technology may impact certain dimensions during the construction phase.

1.4.1 ACCESS

Access to the site is through gravel roads accessed from the R101 via the N1 or R45 (Figure 3).

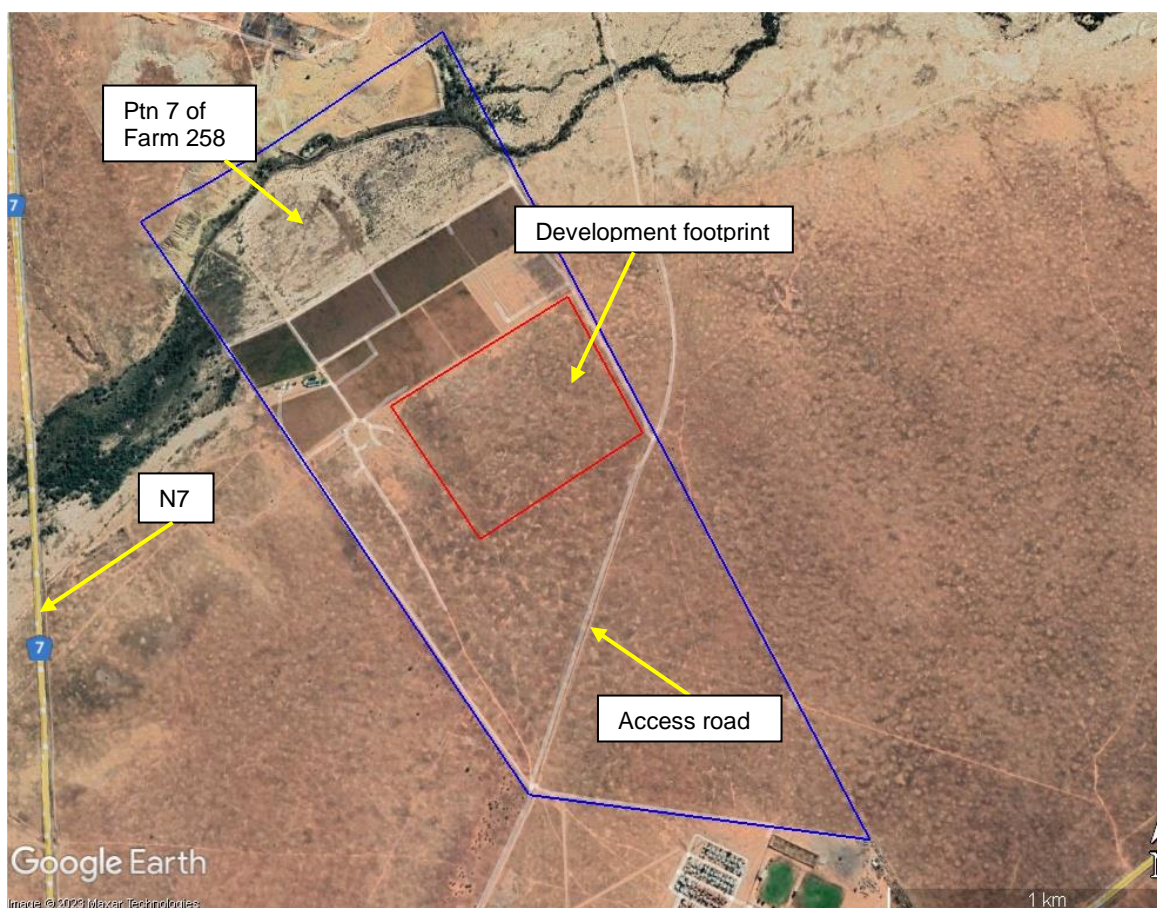

FIGURE 3: Google Earth image of the development site (indicated by the red polygon) on portion 7 of the farm De Duinen 258, Vanrhynsdorp (indicated by the blue polygon).

1.5 THE RECEIVING ENVIRONMENT

Parts of the property have been disturbed by current and past agricultural activities, through livestock grazing. Portions of the property are generally natural or near natural, but indicate severe signs of drought stress.

The topography is also ideal, as the property is generally flat, with very little gradient.

1.5.1 VEGETATION TYPES EXPECTED

According to the Vegetation map of South Africa, Lesotho and Swaziland (Mucina & Rutherford, 2006, as updated in the 2012 beta version and 2018 Final) the vegetation type expected on the proposed site is Gannabosveld (Least Concern).

According to biodiversity overlay maps from SANBI BGIS the site does not fall within a Critical Biodiversity Area (CBA). The majority of the site falls within an Ecological Support Areas (ESA1 & ESA2).

The DFFE Screening Tool Report identified the site as having a Very high Terrestrial Biodiversity Sensitivity, due to the area being identified as an Ecological Support Area.

1.5.2 SURFACE WATER

No watercourses were found on the site. The Droë River is approximately 850m north-north-west of the proposed site.

The DFFE Screening Tool Report identified the site as having a Low Aquatic Biodiversity Sensitivity.

1.5.3 ARCHAEOLOGICAL, HERITAGE AND PALAEOLOGICAL RESOURCES

Based on the NID submitted January 2023, HWC confirmed that there is no reason to believe that the proposed amendment on Portion 7 of the Remainder of the Farm De Duinen No. 258, Vanrhynsdorp will negatively impact heritage resources and no further action under Section 38 (8) of the National Heritage Resources Act (Act 25 of 1999) is required. The material is given a 'General' protection C (Field Rating IV C). This means that it has been sufficiently recorded (in Phase 1). Therefore, it requires no further action.

1.5.4 ANIMALS AND AVIFAUNA SPECIES

The rating of High Sensitivity for the animal species on the DFFE Screening Tool is due to the potential presence of sensitive species. No animal or avifauna species of significance was found on the site according to the terrestrial biodiversity study.

1.6 RECOMMENDATIONS ON IMPACT MITIGATION/MINIMISATION

The following are site/project specific impact mitigation measures recommended by the Specialists and must be enforced if the proposed development were approved.

- The construction and operational phase of the project must be done in accordance with this environmental management programme, the aim of which is, to minimise environmental impact during the construction and operational phases.
- A suitable qualified ECO must be appointed to oversee the construction phase.

The following mitigation measures are recommended by the EAP:

- All construction must be done in accordance with an approved construction and operational phase Environmental Management Plan (EMP), which must include the recommendations made in this report.
- A suitably qualified Environmental Control Officer must be appointed to monitor the construction phase in terms of the EA and the construction phase EMP and any other conditions pertaining to specialist studies.
- Before any work is done the development footprint and access routes must be clearly demarcated and approved by the ECO. The demarcation must include the total footprint necessary to execute the work, but must aim at minimum disturbance.
- Indiscriminate clearing of any area outside of the construction footprint must be avoided.
- Any areas impacted as a result of construction outside of the development footprint must be rehabilitated on completion of the project.
 - This includes the removal of all excavated material, spoil and rocks, all construction related material and all waste material.
 - It also included replacing the topsoil back on top of the excavation as well as shaping the area to represent the original shape of the environment.
- An integrated waste management approach must be implemented during construction.
 - Construction related general and hazardous waste may only be disposed of at Municipal approved waste disposal sites.
 - All rubble and rubbish should be collected and removed from the site to a suitable registered waste disposal site.
- Special attention must be given to alien and invasive control within the construction footprint.

- Care must be taken with the eradication method to ensure that the removal does not impact or lead to additional impacts (e.g. spreading of the Alien Invasive Plants due to incorrect eradication methods);
- Care must be taken to dispose of alien plant material responsibly.

According to the Terrestrial study the following recommendations are key to mitigating the impacts from a biodiversity perspective:

The terrestrial Biodiversity impact assessment suggests that the proposed Vanrhynsdorp development is expected to have a Low cumulative impact (even without mitigation). The evaluation considers the relatively small size of the proposed development and its location adjacent to existing agricultural land (transformed land).

Even though the impact is already considered low it will still be possible to reduce direct impacts during construction. The potential impact on the regional status of the vegetation type and associated biodiversity features (e.g., corridor function or special habitats) is considered low. No irreversible species-loss, habitat-loss, connectivity or associated impact can be foreseen from locating and operating the solar facility on the proposed site. With mitigation the impact on biodiversity features can be reduced but will stay Low.

The proposed development will result in the permanent transformation of <20ha of natural veld covered by a vegetation type considered least threatened. There are no special habitats within or near the proposed footprint that will be impacted by the development (even though it falls within the Knersvlakte Centre of Endemism). It is highly unlikely that the proposed development will have any significant impact on protected or endangered fauna or flora.

The proposed development is unlikely to result in any significant impact and with good environmental control, the development is likely to result in a Low impact on the environment. With the correct mitigation it is considered highly unlikely that the proposed development will contribute significantly to any of the following:

- Significant loss of vegetation type and associated habitat.
- Loss of ecological processes (e.g., migration patterns, pollinators, river function etc.) due to construction and operational activities.
- Loss of local biodiversity and threatened plant species.
- Loss of ecosystem connectivity in the operational phase, areas that were used in the construction phase as laydown areas but that would not be used later i.e. during the operational phase and beyond, must be rehabilitated. This can be achieved by sowing a suitable mix of grasses onto the disturbed areas.

The proposed development site is not considered sensitive in terms of terrestrial biodiversity. As a result, impact minimisation should focus on mitigation measures during construction (and operational) phases, of which the overriding goal should be to clearly define the final layout and to minimise the disturbance footprint.

- All construction must be done in accordance with the approved construction and operational phase Environmental Management Plan (EMP).
- A suitably qualified Environmental Control Officer must be appointed to monitor the construction phase in terms of the EMP and any other conditions pertaining to specialist studies.

- Before any work is done the footprint must be clearly demarcated. The demarcation must aim at minimum footprint and minimisation of disturbance.
- All alien invasive species within the footprint and or within 10 m of the footprint must be removed responsibly.
 - Care must be taken with the eradication method to ensure that the removal does not impact or lead to additional impacts (e.g., spreading of the AIP due to incorrect eradication methods);
 - Care must be taken to dispose of alien plant material responsibly.
- Topsoil (the top 15-20 cm) must be removed and protected and re-used for rehabilitation purposes of suitable areas on site or within the immediate surroundings (Seedbed protection).
- Lay-down areas or construction camp sites must be located within areas already disturbed or areas of low ecological value and must be pre-approved by the ECO.
- Indiscriminate clearing of any area outside of these footprints may not be allowed.
- All construction areas must be suitably rehabilitated on completion of the project.

For the proposed solar and hydrogen amendment, no further Heritage impact assessment or mitigation measures is required.

The following recommendations were made in the previous HIA 2017 (Appendix 4B) for the Archaeological features, taking into consideration any existing or potential sustainable social and economic benefits:

- The footprint area across the northern portion of the site should be re-surveyed once the vegetation has been cleared from the site. Archaeological visibility will be much higher and many more stone tools are likely to be encountered on the ironstone gravels which overlie this portion of the farm. These should be documented before any physical construction takes place on the site, so as to record a more representative sample of the archaeological remains.
- Should any unmarked human burials/remains or ostrich eggshell water flask caches be uncovered, or exposed during construction activities, these must immediately be reported to the archaeologist (Jonathan Kaplan 082 258 0172), or the South African Heritage Resources Agency (SAHRA 021 462 4502). Burials must not be removed or disturbed until inspected by the archaeologist.

The following mitigation recommendations were provided by the previous Palaeontological Impact Assessment 2017:

- Should any substantial fossil remains (e.g. vertebrate bones and teeth, shells, petrified wood) be encountered during excavation, however, these should be reported to SAHRA for possible mitigation by a professional palaeontologist.

For the proposed solar and hydrogen amendment, no further agricultural impact assessment or mitigation measures is required.

The following recommendations were made in the previous Agricultural Potential survey 2017 (Appendix 4C):

- Erosion must be controlled through adequate mitigation and control structures.
- Impacts from vehicles, such as spillages of oil and hydrocarbons, should be prevented and mitigated.

- Dust generation on site should be mitigated and minimised as the dust can negatively affect the quality of pastures as well as sheep production.

According to the Visual Impact Assessment no mitigation is required.

According to the Socio-economic Impact Assessment (**Appendix 4E**), in order to ensure that the disadvantages are managed to maximize positive impacts, specific management strategies and mechanisms need to become part of the proposed development of which some are already practiced as they are required by legislation applicable to the proposed development.

These strategies and mechanisms need to be implemented through development conditions pertaining to:

- Preferential procurement of goods, services and labour,
- Skills transfer
- Security control
- Safety Management
- Traffic Regulation
- Dust and noise control
- Enhancing the economy
- Maintaining Sense of place and Conservation Management
- Protect Agricultural land and activities
- Maintaining Social benefits
- Mitigating Retrenchments.

To implement the strategies and mechanisms, the development should enable the administration thereof. The administration of the strategies and mechanisms should be in partnership with the local authority.

The recommendations follow below.

Preferential procurement of goods, services and labour

Construction, Operation and Demolition Phases:

- Contractors, employing or seeking to employ local HDIs who are suitably qualified, should get preference;
- The municipality, local community and local community organizations should be informed of the project and potential job opportunities by the developer;
- The developer should, where necessary, assist local HDI owned firms to complete and submit the required tender forms on condition that local labour is used;

Construction and Operation Phase:

- Reserve a number of jobs for women and youth: Ensure contractor employ at least 90% locals of whom 80% were previously disadvantaged.
- Facilitate mechanisms to enable women and youth to access employment.
- Pay men and women doing and youth the same job, equally.
- Ensure that women gain equal access to training and education opportunities that men do.

Construction and Demolition Phase:

- A database of locally based firms, including SMME's owned and run by HDIs that qualify as service providers (construction companies, catering companies, waste collection companies, site cleaning companies etc.) should be compiled by the developer prior to the commencement of the tender process. These firms should be invited to bid for tenders;
- Establish a Monitoring Committee for the construction and decommissioning phase in collaboration with representatives of the local community. The Monitoring Committee has to ensure that the proposed solar and hydrogen facility is implemented and that any problems that arise which are associated with the construction and decommissioning phase are addressed.
- Developer and contractor to act as reference for locals employed.
- Developer and contractor to liaise with existing or future projects to access employment for locals.
- Reserve a number of jobs (90%) for local labour (un- & semi-skilled labour).
- Facilitate mechanisms to enable locals to access employment and learning opportunities offered by the proposed solar and hydrogen facility.

Operation and Demolition Phase

- Developer and contractor to act as reference for locals employed.
- Developer and contractor to liaise with existing or future projects to enhance employment opportunities for locals.

Skills transfer

Construction Phase:

- The proposed development should enhance formal and informal skills transfer:
 - Should skilled persons from outside the community be employed, the developer should consider implementing a training and skills development programme to enhance the opportunities for local historically disadvantaged individuals in the construction and maintenance industry. Measures should be put in place to ensure successful training and development i.e., structured job shadowing and learnerships. Such a programme should be offered in liaison with an accredited Further Education and Training College like the West Coast College or University.
 - Some basic skills can be tutored at school level in a joint venture established by the developer between the primary schools in Vanrhynsdorp and the schools or education and skills training providers. In the long term (generationally) the improved skills level will ultimately lead to improved levels of education.

- An “access to education support service” assisting future students should be considered attending to application fees for bursaries, career and financial planning and strategies for the period of studying.
- The proposed development should invest in teacher training to offer scarce subjects such as mathematics, science and physical science. Besides investing in teacher training the proposed development should fund the tuition of the scarce subjects.

Operational Phase:

- Skills transfer and development, formally and informally, should be implemented together with local education and skills training providers (e.g., job shadowing).
- Facilitate mechanisms to enable local young people to access the educational opportunities to attend courses in scarce subjects.
- Ensure local employees do benefit from on-the-job training.
- The educational opportunities should include formal and informal education.
- On successful completion of subjects and courses, opportunities to access further education should be made accessible.
- Facilitate mechanisms to enable local young people (who are not necessarily employed) to access the skills training opportunities.
- On the job training should include formal and informal training opportunities.

Security Control

Construction phase:

- Regularly alternated twenty-four-hour security to guard the development.
- Documentation of all movement and vehicles entering and leaving the premises.
- Regular searching of all vehicles entering and leaving the premises.
- No persons not concerned with the development to enter on the premises.
- Limit access points to one point.

Safety Management

Construction and Demolition Phases:

- Adhere to international construction health and safety standards and precaution measures.
- Provide health and social training amongst the project team and in the community which include HIV/AIDs and Covid awareness training.

Traffic Regulation

Construction and Demolition Phase:

- Rehabilitate the gravel road during and particularly after construction and decommissioning to at least the same standard as is currently.

- Upgrade road signs to address the movement conflict.
- Road signs for protecting pedestrians crossing and accessing the road should be displayed.
- Provide transport to decrease pedestrian traffic.
- Restrict heavy vehicles to specific hours.
- Erect road signs signal times when heavy vehicles will make use of the road.

Construction

- Adhere to national traffic safety standards and precaution measures.
- Contractor/ Implementation agent to provide a traffic safety awareness programme amongst the project team and the community, particularly the kids

Dust and Noise control

Construction and Demolition Phases:

- Dust creation must be controlled as per construction and demolition management and control code.
- Noise creation should be controlled as per construction and demolition management and control code.
- Appoint an Environmental Control Officer to supervise construction and building and demolition.
- Adhere to the Environmental Management Plan (EMPr) for the Construction and Decommissioning Phase.
- All workers and management must undergo an induction course.
- Any natural habitat destroyed by constructing infrastructure should be rehabilitated.
- Enforce strict operating hours for heavy vehicles and construction activities on site to reduce noise and dust impacts on adjacent landowners.
- Implementation dust suppression measures;
- Access must be on recognized routes.
- Litter and littering must be strictly controlled.
- All construction waste and building rubble and demolition waste and rubble must be removed off site.

Enhancing the economy

Construction, Operations and Demolition Phases:

- Contractors should be directed by tender criteria to purchase locally and to make use of local service providers.
- Spending money locally purchasing from locals and South African should benefit employees. The proposed development should leverage discount in the local economy of the municipal area and employees should be made aware of it.
- Small business should be supported (i.e., skills training, assistance and guidance to set up small businesses) and joint ventures with previous disadvantaged persons should be promoted.

- The promotion of joint ventures between small business (owned by previous disadvantaged persons) and more established business should be encouraged.

Operational Phase:

- Market the solar and hydrogen facility as a tourist destination.
- Create links with other tourism activities in Vanrhynsdorp through a website and the local tourism office.
- The promotion of joint ventures between small business (owned by previous disadvantaged persons) and more established business.
- Implement formal small business training and mentoring programmes.
- Ensure the compilation of a management plan (EMPr)

Maintenance of Sense of place:

Design and Planning Phases:

- Prepare an Environmental Constraints Plan to establish the environmental sensitive areas and those areas upon which the development may occur.
- Design buildings to reflect the local architecture and sense of place of the environment. Buildings and similar structures must be in keeping with regional planning policy documents, especially the principles of critical regionalism, namely sense of place, sense of history, sense of nature, sense of craft and sense of limits.
- Should it be required, install anti-reflective coating or glass to reduce the sunlight that is reflected and increase the amount of sunlight that is absorbed.
- Consider installing all electrical cables underground enroute to the substation.
- Where cables cannot be laid underground and electricity towers (pylons) need to be erected, install H-frame wooden poles, or similar structures, to transmit electrical lines instead of steel towers.

Construction and Operational Phases:

- An Environmental Control Officer (ECO) must be appointed to oversee the construction process and ensure compliance with conditions of approval.
- Contractor to sign and undertake to comply with Environmental Specifications
- Demarcate sensitive areas and no-go areas with danger tape to prevent disturbance during construction.
- Pre-construction keep disturbed areas to a minimum. No clearing of land to take place outside the demarcated footprint. Keep disturbed areas to a minimum.
- Throughout construction, identify suitable areas within the construction site for fuel storage, temporary workshops, eating areas, ablution facilities and washing areas.
- Throughout construction institute a solid waste management programme to minimize waste generated on the construction site and recycle where possible.

- Throughout construction reduce and control dust using approved dust suspension techniques as and when required.
- Construction to occur only during daytime. Should the ECO authorize night work, low flux and frequency lighting shall be used.
- Throughout construction, rehabilitate all disturbed areas in accordance with the development plan. Clear all alien vegetation.
- A photographic record of the site and its immediate surrounding area must be kept as part of the EMPr to serve as a baseline for measurement of all future visual impacts and as an aid to the full rehabilitation of the site should the facility be decommissioned in future.
- Excavation on the site is to be kept to the absolute minimum required for the successful implementation of the project.
- Outdoor lighting must be strictly controlled so as to prevent light pollution: Any necessary lighting must be shielded in such a way (such as trees and buildings or structures) that no direct light is allowed to escape into the surrounding terrain or up into the sky (All lighting must be installed at downward angles). Only the areas that are necessary to be lit must be lit with the surrounding. Use only minimum wattage light fixtures, such as trees and buildings or structures
- Utilize existing roads and tracks to the maximum extent possible.
- Provide where practical, pedestrian walkways where desire lines are identified.
- Visual management and maintenance: Scheme maintenance covering site tidiness should be maintained at all times including during construction.
- Buildings and similar structures must be in keeping with regional planning policy documents, especially the principles of critical regionalism, namely sense of place, sense of history, sense of nature, sense of craft and sense of limits.

Operational Phases:

Apply the following urban design indicators and guidelines:

- Maintain the general appearance of the facility as a whole (i.e., the PV panels, buildings and associated infrastructure, roads and natural environment).
 - Littering is to be strictly controlled over the entire life of the project
 - All waste is to be regularly removed from facility to a recognized dumping site. Waste, in any form, should not be allowed to collect on the site.
 - Visual management and maintenance: Scheme maintenance covering site tidiness should be maintained at all times including during construction.
- Monitor land surface below PV 'strings' to prevent loss of vegetation and first signs of desertification.
 - The use of any cleaning materials or defoliants to aid in the control of vegetation is to be strictly monitored so that their long-term use does no cause future problems should the site be decommissioned.
 - The solar cleaning materials must be environmentally friendly and biodegradable.
- Maintain access roads to prevent scouring and erosion, especially after rains.
 - Utilize existing roads and tracks to the maximum extent possible.

- Provide pedestrian walkways where desire lines are identified.
- Monitor the use of lighting over the entire life of the project to minimize light pollution.
 - Strictly control outdoor lighting to prevent light pollution.
 - All lighting must be installed at downward angles.
 - Sources of light must as far as possible be shielded by physical barriers such as a planted trees and shrubs or built structures. Plant a screen of endemic bushes and trees together with fencing in natural colour and good plant maintenance. (Interface integration of proposed solar and hydrogen facility with surroundings).
 - Consider the application of motion detectors to allow the application of lighting only where and when it is required.
 - Only minimum wattage light fixtures must be used.
- A strict fire prevention policy must be implemented and monitored.

Decommission phase

- Prepare a decommissioning plan to establish a timeframe and order of decommissioning and rehabilitation of the plant.
- During demolition the site should be returned to as near as its existing state as is possible.
- All waste material has to be removed.
 - Removal of all infrastructure introduced into the landscape (i.e., PV panels, ancillary infrastructure such as a maintenance workshop, storage building and offices).
 - Rehabilitate all new access roads created during the construction period.
 - Institute monitoring of all decommissioned and rehabilitated sections of the project site at regular intervals.

Protect Agricultural Potential and Water Sources

Construction Phase:

The site should be developed with as little disturbance as possible to be able to rehabilitate it back to its natural form.

- Control vehicle access and constructional activity on roads and minimal footprint areas only.
- Strip and stockpile topsoil from all areas where soil will be disturbed. After cessation of disturbance, re-spread topsoil over the surface.
- Dispose of any sub-surface, clay spoils from excavations where they will not impact on vegetated land, or where they can be effectively covered with topsoil.

Operational Phase:

- Implement an effective system of storm water run-off control at any point where run-off water might accumulate. The system must effectively collect and safely disseminate any run-off water from all accumulation points and it must prevent any potential down slope erosion.
- Any occurrences of erosion must be attended to immediately and the integrity of the erosion control system at that point must be amended to prevent further erosion from occurring there.

- Maintain where possible all vegetation cover and facilitate re-vegetation of uncovered areas throughout the site, to stabilize disturbed soil against erosion, and to reduce dust formation.
- If an activity will mechanically disturb the soil below surface in any way, then any available topsoil should first be stripped from the entire surface to be disturbed and stockpiled for re-spreading during rehabilitation. During rehabilitation, the stockpiled topsoil must be evenly spread over the entire disturbed surface, and then stabilized by facilitating vegetation cover.
- Enhance on-site conservation where appropriate.

Construction, Operation and Decommissioning Phases

- Implement an effective system of run-off control which collects and disseminates run-off water from hardened surfaces and prevents potential down slope erosion (all phases).

Maintaining Social Benefits

Decommissioning Phase:

- The social benefit fund should explore partnership and other sources of funding.
- Some funds should be invested as a source for future support to local children.

Mitigate Retrenchments

Decommissioning Phase:

- During the contract period, provision should be made for those employed to obtain additional skills set.
- Effort should be made to obtain placement for contract workers in either their current or their alternative field of expertise.
- The developer should establish a fund from which these contractors could benefit.
- The established Monitoring Committee for the construction and demolition phases in collaboration with representatives of the local community, has to ensure that that the EMP is implemented and the solar and hydrogen facility is decommissioned and that any problems that arise and is associated with the decommissioning phase, is addressed.

1.7 ENVIRONMENTAL AUTHORISATION

The Conditions of approval of the Environmental Authorisation (EA) and other relevant approvals/licences from other authorities will be included as Appendix 1 in the final EMP. The conditions of approval must be adhered to as part of the EMP.

EA (Environmental Authorisation) Conditions of Approval – Appendix 1.

2. DEFINITIONS AND ABBREVIATIONS:

2.1 DEFINITIONS

Applicant: The person or responsible person from an organization who applied for the proposed activity described in the Environmental Authorisation.

Audit (Site Completion): Environmental Site Inspection and verification of construction activities to EMP

Bund: Enclosure under / around a storage facility to contain any spillage

Batch plant: a concrete or plaster mixing facility and associated equipment and materials.

Construction: means the period of the project during which the actual works are carried out, deemed to include site establishment, site preparation, the works, maintenance period and decommissioning.

Construction phase: The construction phase period of a cellular communications Construction site is defined as from the commencement of site establishment up to and including the practical site handover.

Construction site: means the area influenced and affected by the construction activities or under the control of the Contractor often referred to as "the Site".

Construction Supervisor: The person responsible (appointed by the owner) to ensure that the construction is carried out to completion on time, within budget and that the Contractor fulfils his obligations in terms of the EMP.

Contaminated water: means water contaminated by the Contractor's activities, e.g. concrete water and runoff from plant/ personnel wash areas.

Contractor: the principal persons / company and all other sub-contractors involved in the construction of the project.

Contractor's camp: means the designated and suitably demarcated areas on the Site within which all site offices and staff facilities are situated and within which equipment will be stored, for instance, batching plant, crusher plant, sand washing plant, workshop, offices, rest areas, ablution areas, etc., whichever is applicable.

Declaration of understanding: Form that is signed by all contractors involved in the construction works of their understanding and acceptance of the EMP and site-specific additions to the EMP.

Development site: boundary and extent of development works and infrastructure.

Environment: means the surroundings within which humans exist and that are made up of:

- the land, water and atmosphere of the earth;
- micro-organisms, plant and animal life;
- any part of the combination of the above two bullets and the interrelationships between them;
- the physical, chemical, aesthetic and cultural properties and conditions of the foregoing that influence human health and well-being

Environmental Aspect: Any element of any construction activity, product or services that can interact with the environment.

Environmental Audit Report: report done by the ECO and submitted by the Applicant to the satisfaction of the Chief Directorate Environmental Affairs, within six months after construction has been completed and also after the site(s) has been rehabilitated.

Environmental Control Officer: The registered Environmental Scientist (*in terms of section 20(3) of the Natural Scientific Professions Act, 2003 (Act 27 of 2003)*) responsible for overseeing the environmental aspects of the Construction phase of the EMP.

Environmental Completion Statement: A report by the ECO to the relevant authorities stating completion of the project and compliance with the EMP and its conditions.

Environmental Impact: Any change to the environment, whether adverse or beneficial, wholly or partially resulting from any construction activity, product or services.

Method statement: A statement by the Contractor, describing the scope of intended construction works step-by-step, in order for the ECO and Construction Supervisor to understand the Contractors intentions and be able to comment on, so that they could assist with devising mitigating measures should it be necessary to avoid environmental impact.

No-Go Area(s): An area of such (environmental/aesthetical) importance that no person or activity are allowed within a designated boundary surrounding this area.

Owner: The owner, or dedicated person, responsible for the management of the property on which the proposed activity (in terms of the ROD) will be performed.

Stop Works Order: An order which can be issued either by the ECO or Construction Supervisor to the Contractor (or any sub-contractor) if serious environmental damage is about to happen or is happening as a result of construction activities. On receiving such an order the Contractor must immediately stop all activities (or planned activities) relevant to the specific issue until an environmentally friendly resolution has been approved by the ECO.

Site: The area and extent of the development works and infrastructure, including any areas off the main site on which works are to be carried out in order to allow the development to proceed successfully.

Site meetings: Periodic (weekly or monthly) meetings between the ECO, Construction Supervisor and Contractor to discuss construction activities that relate to the environment or any other environmental issues that might arise.

Works: The works to be executed in accordance with a contract.

On-site start-up meeting: a start-up meeting held on site, before any construction has begun to discuss EMP and determine site specific additions that will be included as the basis for the EMP.

Potentially hazardous substance: is a substance, which, in the reasonable opinion of the Engineer, can have a deleterious (detrimental) effect on the environment.

Method statement: is a written submission by the Contractor to the Engineer or relevant responsible person

Reasonable: means unless the context indicates otherwise, reasonable in the opinion of the Engineer/Project Leader after he has consulted with a person, not an employee of the client, suitably experienced in "environmental implementation plans" and "environmental management plans", both as defined in the Environmental Management Act (Act No 107, 1998).

Solid waste: means all solid waste, including construction debris, chemical waste, excess cement/concrete, wrapping materials, timber, tins and cans, drums, wire, nails, food and domestic waste (e.g. plastic packets and wrappers).

Precautionary principle: means the basic principle, that when in doubt or having insufficient or unreliable information on which to base a decision, to then undertake actions that will have minimum risk.

2.2 **ABBREVIATIONS**

CARA	Conservation of Agricultural Resources Act, 1983 (Act no. 43 of 1983)
CEMP	Construction phase Environmental Management Plan
DFFE	Department of Forestry, Fisheries and the Environment
ECO	Environmental Control Officer: - Must be a suitably qualified independent environmental consultant appointed to ensure compliance to the EMP
EMP	Environmental Management Plan or Programme
ESO	Environmental Site Officer - Must be a person with adequate environmental knowledge to understand and implement the EMP by conducting on site inspections determined by the ECO and the client.
ER	Engineers representative or Main contractors representative
EA	Environmental Authorisation (Record Of Decision) issued by relevant authority for the authorisation to commence construction under certain environmental compliances
MSDS	Material Safety Data Sheet(s)
NEMA	National Environmental Management Act, 1998 (Act no. 107 of 1998)
OEMP	Operational Environmental Management Plan
OSSM	On-site Start-up Meeting
ROD	Record of Decision
SAHRA	South African Heritage Resources Agency

3. CONSTRUCTION PHASE EMP

3.1 STRUCTURE AND RESPONSIBILITY

Implementation of the EMP and environmental control and management of the construction phase will be achieved through the responsibility structure set out below. The role players include the Owner, the Construction Supervisor, the Environmental Control Officer and the Contractor. All role players must familiarize themselves with the prescriptions of the EMP.

3.1.1 THE CLIENT / APPLICANT / OWNER

The client (or the designated responsible person appointed by him) is responsible for:

- appointing a suitably experienced ECO, the Construction Supervisor and the Contractor for the duration of the construction contract, and
- ensuring that the Construction Supervisor and Contractor fulfil their obligations in terms of this EMP.

3.1.2 THE CONSTRUCTION SUPERVISOR

The Construction Supervisor is responsible to ensure that the construction is carried out to completion on time, within budget and that the Contractor fulfils his obligations in terms of the EMP. In addition, the Construction Supervisor and the ECO are expected to develop a close working relationship and to stay in contact with each other.

The responsibilities of the Construction Supervisor include:

- To issue site instructions to the Contractor.
- To serve as conduit for all communication between the ECO and the Contractor [The only exception is where the ECO or the Construction Supervisor needs to issue a “**STOP WORKS**” order on the contractor if serious environmental harm is about to happen or is happening as a result of construction activity. The “**STOP WORKS**” order must be confirmed by the other party as soon as reasonably possible].
- Discussing any problems that might lead to environmental damage with the ECO.
- When the ECO is not on site the Construction Supervisor will be responsible for the implementation of the EMP.

3.1.3 THE CONTRACTOR

The Contractor shall be responsible to:

- ensure that all sub-contractors, employees, suppliers, agents etc. are fully aware and adhere to the environmental conditions detailed in the EMP;
- liaise closely with the Construction Supervisor and the ECO;
- ensure that works on the site are conducted in an environmentally sensitive manner and in full accordance with the EMP;
- carry out instructions issued in the site instruction book;
- assist with solutions to environmental problems that may arise during the construction phase; and
- ensure that all “**No-Go**” areas are adequately fenced off.
- will report any deviation from the requirements of this EMP to the Principal Agent, and any pollution or environmental contaminant spill events.
- agrees to work stoppage and/or payment of penalties as required by this EMP and directed by the ECO/Construction Supervisor.

- agrees bear full costs for any work stoppage resulting from contravention of the requirements of this EMP, and/or the costs of remedying environmental damage resulting from their or their sub-contractors or employee's contravention of the requirements of this EMP.

NB: All contractors must sign the "Declaration of understanding" (page ii of this document) of this Environmental Management Plan before construction commences.

3.1.4 THE ENVIRONMENTAL CONTROL OFFICER (ECO)

ECO will be responsible for overseeing the environmental aspects of the Construction phase and will work in close co-ordination with the Construction Supervisor.

3.1.4.1 ECO qualifications

The ECO must be independent and suitably qualified (a diploma or degree in environmental management with at least 5 or more years of environmental site management experience) and must have a sound knowledge of the environment in which the activity will take place.

3.1.4.2 ECO duties

An ECO must be appointed for the duration of the construction phase (as required by the EA). The ECO:

- will be primarily responsible for ensuring the implementation of the EMP and will perform regular site inspections/audits with the specific aim to ensure environmental conformance by the Contractor;
- to visit the site on a regular basis while construction is in progress. Frequency of site visits is recommended at 1 x site visit every 2 weeks, or as determined by the Competent Authority;
- will keep environmental records (including photographs) of the construction activities;
- must ensure that "No-Go" and "Open Space" areas are adequately protected and adhered to;
- must approve and be present during the demarcation of the necessary areas for storage of materials, ablutions, eating areas of contract workers etc;
- to conduct a start-up meeting before construction commences and will provide environmental training at the beginning of the project and will provide environmental awareness training throughout the life of the project;
- must be informed of site and technical meetings to be able to comment and report on environmental issues;
- will call for, and approve, method statements for construction activities that might pose an environmental impact and must ensure that method statements are approved before commencement of the work;
- must implement immediate mitigating action in the case of critical environmental impacts
- must deal with public complaints/queries regarding environmental issues;
- will record his findings and all environmental non-conformances in an environmental completion report (which will be forwarded to the Client and the Construction Supervisor);
- will conduct a closing down visit as soon as possible after completion of the Development;
- will commission an independent Environmental Compliance Audit within 6 months after completion of the contract.

3.1.4.3 ECO Authority

The ECO has the authority to stop works if there is a serious threat to or impact on, the environment as a direct cause of construction. However, this authority is limited only to emergency situations where immediate consultation with the Construction Supervisor is not possible.

- The ECO is to inform the client/developer and site representative of the reasons for the stoppage as soon as possible. A relevant reason should be supplied as soon as possible after stoppage of such works.
- Upon failure by the contractor or his employee to show adequate consideration to the environmental aspects of this contract i.e. wilful destruction of the environment, the ECO may recommend to the client/developer or site representative to have the contractor's representative or any employee(s) removed from the site or work suspended until the matter is remedied.
- No extension of time will be considered in the case of such suspensions and all costs will be borne by the contractor.

3.1.5 HEALTH & SAFETY OFFICER:

A Health & Safety (H&S) Officer for the project must be designated or appointed by the Contractor or Principal Agent, and his/her role is to support the successful implementation of the EMP through:

- Site evaluation on a regular basis.
- Identifying issues relating to day to day construction activities and that can have a detrimental effect on the environment.
- Subcontractor audits to ensure compliance.
- Assist in the direct implementation of the EMP.
- Ensure that the requirements of the EMP are communicated understood by personnel on site *via* induction sessions.
- Ensure that the contractors on site develop, implement and monitor the required H&S management functions.
- Evaluate the applicability and accuracy of the EMP and the method statements throughout the construction phase.
- Coordinate all statutory requirements including permit authorisation and license requirements.
- Conduct or have conducted a hazard analysis and take the necessary corrective action.
- Where it is not possible to remove any remaining hazard's to inform employees thereof and what precautionary action is to be taken.
- Detail mitigation measures required to be taken, and the procedures for their implementation to the project manager.
- Representing H&S issues at the production meetings.
- Coordinate H&S training of personnel.
- Coordinating spill response personnel.
- The H&S officer shall inspect the integrity of the hazardous waste containers/bins/skips on a weekly basis.
- The H&S officer shall inspect the integrity of the hydrogen storage containers on a regular basis as required / determined by safety guidelines

3.1.5.1 Health & Safety Officer qualifications

The Health and Safety Officer must be independent and suitably qualified, with a sound knowledge of the Occupational Health & Safety Act (Act no. 85 of 1993), and must have experience of the implementation of the act with regards to the construction and environmental environments in which the activity will take place.

3.2 COMMENCEMENT OF WORKS

The site project contractors must timeously receive a copy of the construction phase EMP (CEMP) and any other further additional information that pertains to site conditions/amendments or deviations from original site plan.

- This EMP must be included to form part of the Contractors site specification documentation.
- A copy of the EMP must be on site at all times and available for presentation to any authority requesting to see such document.

NO WORK ON SITE MAY TAKE PLACE UNTIL:

- The Declaration of Understanding/Environmental Contract is signed between the relevant parties.
- At least one week's written notice (or as specified in the EA) given to the Department before commencement of any construction activity (As per EA).
- On-Site Start-Up Meeting has been held
- Site and No-Go areas has been identified **and demarcated**.
- Contractors are in possession of the EMP and other relevant documentation
- Contractors/Sub contractors have signed the Declaration Of Understanding
- All mandatory site equipment is in place
- On Site Environmental Education & Awareness training session has taken place with all relevant construction personnel present.

NB: Work refers to: Camp Establishment, Earthmoving activities and any pre-liminary construction activities.

3.3 ISSUES OF CONCERN

Issues of concern that were identified in the Environmental Impact Assessment process and included in the EA or detailed in the Basic Assessment Report must be addressed during the "On Site Start-Up Meeting" and must be included in the On-Site Start-Up Report. Issues of Concern include but shall not be limited or restricted to the following:

- Site demarcation
- Demarcation and protection of "no-go areas"
- Establishment of temporary laydown areas
- Waste management and disposal
- Mandatory site equipment
- Establishment of construction site compound
- Above ground bulk fuel storage facilities
- Ablution & Toilet Facilities.
- Refuse Management
- Concrete works & batching plant facilities
- Soil erosion & sediment control
- Fire fighting equipment & emergency fire reaction plan
- Use and storing of hazardous substances
- Rehabilitation

3.4 SITE SPECIFIC ARRANGEMENTS & CONSTRUCTION PROCEDURES

Please note that all recommendations summarized in the Basic Assessment Report must be addressed and read as part of the site specific arrangements & construction procedures which will include:

- General recommendations;
- Site specific mitigations;
- Conditions of approval of the Environmental Authorisation.

3.4.1 ON-SITE START-UP MEETING

The mandatory **On-Site Start-Up Meeting** must be conducted at least **14 days but not less than 5 working days** prior to commencement of any site/camp establishment, earthworks and/or construction activities and will relate to additional discussed information that must be complied with during the entire construction phase.

On-Site Start-Up Meeting points of discussion are:

- The Construction EMP & other relevant site documents
- Project to be discussed and all uncertainties are cleared
- Method statement/s to be discussed
- Power line installation access routes
- Road and construction area to be demarcated
- Materials stockpile and lay down areas to be demarcated
- Method of stockpiling to be discussed
- Fire fighting procedures
- Mandatory fire fighting equipment & fire preventative measures
- Solid waste removal intentions
- Placement, type and service of toilets to be agreed on
- Placement and type of rubbish bins and removal of rubbish to be agreed on
- Labour overnight camp to be demarcated and services agreed on
- Environmental Education and awareness training session to all contractors & onsite staff/labour.
- Location & establishment of concrete batching plant facility.

3.4.2 START-UP MEETING PARTICIPANTS

Minutes of the onsite Start-Up Meeting will be condensed to a report format and circulated to all attendees of the above-named meeting for their perusal and comments. The On-site Start-up Meeting report will form part of this EMP. If any discrepancies between the start-up report and the EMP arise then the EMP will take precedence until clarification on the discrepancy is clarified. If any discrepancies between the EMP and the EA then the EA will take precedence until clarification on the discrepancy is clarified.

Participants to the start-up meeting can include:

- Applicants Representative.
- Main Contractor's Representative.
- Resident Engineer
- Site foreman.
- Environmental Consultant.
- Environmental Control Officer.

NB: It is the responsibility of the main contractors to ensure that all sub- contractors, that work on the site during and after the civil's contract, are informed of the environmental conditions pertaining to the site.

3.5 ENVIRONMENTAL- & AWARENESS TRAINING

3.5.1 ENVIRONMENTAL AWARENESS COURSE

Environmental awareness training courses shall be run for all personnel on site. The ECO will be responsible for the initial awareness course which shall include all relevant management, the Construction Supervisor, the Contractor and all foremen. All attendees shall remain for the duration of the course.

The Contractor shall be responsible to ensure that all his personnel and subcontractors (if applicable) are informed and made aware of the environmental constraints and shall also supply the ECO with a monthly report indicating the number of employees used by him. If refresher courses are deemed necessary, for instance, where personnel disregard the requirements of the EMP, the time lost and the cost of the course would be for the account of the Contractor.

3.5.2 SPECIFIC TRAINING

All contractors and workers shall be informed about any special habitat, biodiversity feature, vegetation and/or rare plant species that might be present on the specific construction site (if applicable).

3.6 METHOD STATEMENTS

Method statements from the contractor will be required for specific sensitive actions on request of the authorities, the Applicant or ECO.

A method statement forms the base line information on which sensitive area work takes place and is a “live document” in that modifications are negotiated between the Contractor and ECO/applicant, as circumstances unfold.

All method statements will form part of the EMP documentation and are subject to all terms and conditions contained within the EMP main document.

These documents must be available to the authorities for inspection or on request.

A method statement describes the scope of the intended work in a step-by-step description in order for the ECO and Applicant to understand the contractor’s intentions. This will enable them to assist in devising any mitigation measures, which would minimize environmental impact during these tasks.

The Contractor must submit the method statement before any particular construction activity is due to start. Work may not commence until the ECO and applicant have approved the method statement.

Method statements need to be compiled by the contractor for approval by Applicant and the ECO. The contractor must submit written method statements to Applicant for the purposes of the environmental specification, a “Method Statement” is defined as a written submission by the contractor to Applicant setting out the plant, materials, labour and method the contractor proposes using to carry out an activity, in such detail that Applicant and the ECO is able to assess whether the contractor’s proposal is in accordance with the specifications and/ or will produce results in accordance with specifications.

The method statement must cover applicable details with regard to:

- Construction procedures
- Materials and equipment to be used
- Getting the equipment to and from site
- How the equipment/ material will be moved while on site
- How and where material will be stored
- Location & establishment of concrete batching plant facility.

- The containment (or action to be taken if containment is not possible) of leaks or spills of any liquid or material (of any potential hazardous material) that may occur
- Timing and location of activities
- Compliance/ non-compliance with the Specifications, and
- Any other information deemed necessary by the Applicant and the ECO

The Contractor must abide by these approved method statements, and any activity covered by a method statement must not commence until Applicant and the ECO has approved of such method Statement.

NB: No work may commence or take place before the Method Statement has been approved by all relevant parties.

List of possible Method statements include but shall not be limited or restricted to:

- Demarcation
- Demarcation and protection of “no-go areas”.
- A traffic management plan for the site access road.
- A transportation plan for the transport of larger components.
- A storm water management plan.
- An erosion management plan.
- Clearing of vegetation & topsoil removal
- Clearing and disposing of alien vegetation
- Stockpiling
- Temporary storage facilities
- Construction camp & site offices
- Fuel storage
- Labourer’s facilities
- Mandatory site equipment
- Waste control
- Cement mixing (if required)
- Construction vehicle maintenance
- Heavy earthmoving equipment
- Dust control
- Noise control
- Rehabilitation

3.6.1 ADDITIONAL METHOD STATEMENTS

Any additional method statements (with regards to a specific aspect of construction) that may be required must be **submitted** and approved before commencement of the specific works and must be available at the site offices.

3.7 NON-COMPLIANCE

Applicant (on recommendation by the ECO) reserves the right at all times for the duration of this agreement to impose restrictions and associate penalties on the contractor with respect to the specific nature, timing and extent of construction activities on environmentally sensitive sites.

3.7.1 CORRECTIVE ACTION INSTRUCTION

The ECO may issue an onsite corrective action instruction to the site agent, or, by means of an entry into the Site Instruction Register for remedial work to be carried out to rectify any non-compliance that has been carried out within a reasonable agreeable time frame to carry out and complete the remedial work.

3.7.2 WRITTEN WARNING

In instances of non-compliance with the EMP by the contractor (or any of their employees) or sub-contractor/s (or any of their employees) that move on or off the site, the onsite ECO must issue a written warning indicating the non-conformance to the contractor.

If repeated instructions by the ECO to the site agent to respond to the corrective action instruction have not been carried out the ECO can issue a Written Warning notation instructing the site agent to timeously carry out the corrective measures as per the original non-compliance.

3.7.3 PENALTY FINES

In the event of the site agent negligence to respond and correct the noted non-compliance the ECO may in collaboration with the relevant parties recommend that a Penalty Fine be imposed on the contractor.

- The applicant, in consultation with the ECO must determine the amount of the penalty applicable in accordance with the Penalties for Non-Compliance Schedule of Tariffs.
- Such penalty amount must be in writing and presented to the contractor within seven (7) days of the written warning.
- Applicant may recover penalties by deducting the fine from the offending contractor.
- The contractor will be responsible for all costs incurred where emergency procedures are implemented to deal with accidents impacting on the environment as well as the rehabilitation of such damage in conjunction with the ECO and site engineer.
- In serious cases, at the discretion of Applicant and the Environmental Consultant/ECO, any multiple offences can be added together.

3.7.4 STOP WORKS

The ECO (after consultation with Environmental Consultant/Applicant/Engineer) may also stop the works or part thereof until the situation is resolved; no extension of time is claimable by the contractor.

These penalties do not preclude any prosecution under any law or regulation.

3.8 CHANGES TO EMP

Although care has been taken to address all known relevant environmental issues for the construction phase, it may become necessary to add or amend certain procedures or instructions to improve the efficiency of the Environmental Management Plan (EMP).

- Only those additions or amendments of this EMP that will either improve environmental protection or can be proved not to have any negative effect to the immediate and surrounding environment will be considered.
- Changes or deviations have to be motivated in writing by means of a Method Statement and the same procedures for a standard Method Statement have to be followed.
- Any additions or amendments must be submitted by the ECO to DEADP (if so requested) after the ECO has consulted with the Environmental Consultant and Applicant.
- No deviation from the contents of the EMP is allowed without the above-named prescribed procedures

3.9 RECORD KEEPING

All records relating to the implementation of this Environmental Management Plan must be kept together, be readily retrievable and available for scrutiny by any relevant authority. Records include the following:

- Declarations of understanding;
- ECO Checklist, audits and/or diary;
- Method Statements
- Environmental incident reports
- Photographs (must be taken before, during and immediately after construction as a visual reference);
- The Environmental completion statement.

These records must be available for scrutiny by any relevant authorities.

3.10 STANDARD MANAGEMENT PROCEDURES

3.10.1 ACCESS & HAUL ROUTES

The Contractor must control all access (vehicles and plant) to and from the construction site, including that of his suppliers so that they remain on the pre-approved designated routes. In addition such vehicles and plant must be so routed and operated as to minimise disruption to regular users of the routes.

- Where heavy duty vehicles and construction plant are required, both the type of vehicles/machinery and the area/s these are to access shall be specified in a Method Statement.
- Access routes/haul roads will utilise only existing roads or tracks, unless such routes are not available or new routes are to be constructed as part of the project, in which case a Method Statement must be submitted for the construction of any new access/ haul roads (including temporary routes).
- No new roads or tracks may be created except where such routes are specifically approved by the ECO, in the EA or in this EMP.
- Any new access roads/haul roads must be designed so as to minimise erosion and must run across slopes and not directly up-hill.
- All vehicles and access to the site must remain within demarcated access routes and working areas on site.
- All reasonable measures must be implemented to minimize impacts on road users.
- On gravel or earth roads on site, the vehicles of the Contractor and his suppliers may not exceed a speed of 25 km/h.
- On public roads adjacent to the site, vehicles will adhere to municipal and provincial traffic regulations.

- Any temporary access routes must be rehabilitated at the end of the contract to the satisfaction of the ECO.

If so required by the owner of the land the following may also apply with regard to access and vehicular movement on site:

- All Contractors, subcontractors and staff shall be identified by clothing with company logos and be in possession of valid SA identity documents.
- Deliveries, removals etc. to be completed during normal working hours (unless otherwise agreed upon by the Construction Supervisor).
- No personnel shall stay permanently on site, unless permission to stay on site provided as part of the construction contract.
- Access route diversions must be clearly demarcated by orange twine/danger tape on steel posts or temporary fencing.
- The Contractor shall at his cost document the existing condition of all access roads prior to commencement.
- Should any damage occur to the access road as a result of the upgrade activities, the road will be rehabilitated to its original state with all costs borne by the contractor.

3.10.2 APPROPRIATE USE OF MACHINERY

Contractor must at all times carefully consider what machinery is appropriate to the task while minimizing the extent of environmental damage.

- The contractor may not operate any machinery including a fuel driven compressor outside the demarcated area.
- All vehicles and equipment must be routinely inspected for fuel and oil leaks and kept in good working order and serviced regularly. Leaking equipment must be repaired immediately or removed from the Site. When servicing equipment, drip trays must be used to collect the waste oil and other lubricants. Drip trays must also be provided in construction areas for stationary plant (such as compressors) and for "parked" plant (such as scrapers, loaders, vehicles). Drip trays will be kept free of water that will float the oil to overspill. All drip trays / bungs to attain a 120% capacity of the plant fuel / oil capacity.
- Where practical, all maintenance of plant and machinery on Site must be performed in workshops. If it is necessary to do maintenance outside of a workshop area, the Contractor must obtain the approval of the Engineer and the ECO prior to commencing activities.
- Appropriate 4.5 kg (minimum requirement) dry powder SABS approved and service certified fire fighting extinguisher must be a mandatory item on all vehicles working and moving on or off the construction site.
- The servicing, repairs and maintenance of all construction machinery must take place at the designated service and maintenance yard and not along the proposed new road construction route.

3.10.3 "No-Go" AREAS

Specifications of the Environmental Authorisation (EA), the Environmental Management Plan (EMP) or the On Site Start-Up Meeting (OSSM) can require that certain areas are to be considered as "No go" areas as a result of their environmental significance or proximity to environmental significant features.

- All areas identified in the site sensitivity overlays as "no-go" areas are to be considered as such, and appropriately demarcated as such.

- All areas of natural vegetation and streams/rivers outside of the development footprint should be considered “no-go” areas.
- A Method Statement is to be submitted to the ECO by the Contractor, detailing the method of demarcation for protection of such conservation areas.
- No-Go areas are out of bounds to the Contractor and his staff, sub-contractors and their staff or suppliers and their staff or any other person involved in the project, without the written permission specified by the ECO.
- The Contractor must ensure that, insofar as he has the authority, no person, machinery, equipment or material enters the designated "No Go" areas at any time.
- All contractors must be made aware of the importance of these features and the consequences of non-compliance. All staff are to be made aware of the “no – go” areas in the induction and environmental awareness training.
- All private property/farms outside of the works area are considered “no-go” areas, unless permission has been received from the ECO and written permission has been received from the land owner.
- Natural vegetation outside of the development area will be considered no-go areas, unless for the purpose of alien vegetation clearing.

3.10.4 RESTRICTION OF WORKING AREAS

The approved layout plans will be used to establish the site demarcation (footprint). All relevant parties responsible for the day-to-day activities on the site will be present and made aware of the implication of the site demarcation. They include the:

- Environmental Consultant: EnviroAfrica
- Principle Agent
- Main Contractor: Project Site Manager
- Sub-contractor: Project contractor
- ECO: Environmental Control Officer

The proposed site will be demarcated prior to the commencement of any construction whatsoever, this includes site establishment, the moving of construction material or any other items onto the site, etc.

- The site will be demarcated with appropriate dropper poles. A single strand of orange baler twine is to be attached to the dropper poles to indicate boundaries and no-go areas for site personnel and vehicular movement. (Alternative fencing may be decided upon dependent on-site requirements). Other demarcation measures can be used if approved by the ECO.
- The construction area i.e. road, stockpile areas and development footprint etc. must be demarcated and fenced off with dropper poles and orange baler twine approximately 1m high is considered adequate. The demarcation will be agreed on during the start-up meeting.
- All fencing and fence placement / positioning must be approved by the ECO on site.
- Work areas and access routes must be clearly demarcated to minimise environmental impact.
- In the event that sensitive features are threatened by construction activities, temporary fencing off of these areas (for individual areas such as trees or rocks) or the construction area (when working in a mainly natural environment) is recommended.
- NB: Also note the requirements discussed under the following paragraphs: 3.10.5; 3.10.2; 3.10.8; 3.10.6; 3.10.7.
- The Contractor must maintain in good order all demarcation, fencing and barriers for the duration of construction activities, or as otherwise instructed.
- Demarcation may not be moved, re-located or altered or changed without the approval of the ECO.

- Any temporary fencing removed for the execution of any portion of the works is to be reinstated by the Contractor as soon as practicable.
- The Contractor at the end of the contract must remove all demarcation, fencing or barriers not forming part of the final works on Site.

3.10.5 PROTECTION OF NATURAL VEGETATION

Habitat fragmentation is usually defined as a landscape-scale process involving both habitat loss and the breaking apart of habitat. Habitat loss has large, consistently negative effects on biodiversity. Habitat fragmentation per se has much weaker effects on biodiversity, but could be just as negative. As such the construction activities must endeavour to minimise its impact on any remaining natural features and natural corridors.

- All significant biodiversity features identified during the environmental assessment stage, must be mapped and identified as “No-Go” areas on the site plans and protected measures must be installed (demarcated). Only alien vegetation clearing may take place within the natural areas outside the demarcated works area;
- Except to the extent necessary for the carrying out of the works, no natural indigenous flora may be removed, damaged or disturbed;
- Trapping, poisoning and/or shooting of animals is strictly forbidden. No domestic pets or livestock are permitted on Site;
- Where the use of herbicides, pesticides and other poisonous substances are to be used, the Contractor must submit a Method Statement;
- The Contractor may not deface, paint, damage or mark any natural features, if these should occur (e.g. trees, rock formations, buildings, etc.) situated in or around the Site for survey or other purposes unless agreed beforehand with the Engineer and the ECO. Any features affected by the Contractor in contravention of this clause must be restored/rehabilitated to the satisfaction of the Engineer and the ECO.
- All incidents of harm to any animal or natural vegetation (apart from the agreed upon areas) must be reported to the ECO.

3.10.6 PROTECTION OF FAUNA AND AVI-FAUNA

Trapping, poisoning and/or killing of animals and birds is strictly forbidden. No domestic pets or livestock are permitted on Site. Many slow-moving animals, local amphibian and other species follow instinctive movements along roadside corridors where they travel from place to place.

- Every effort must be implemented on a daily on-going basis by the contractor to ensure that the construction areas have been checked for any animals and to ensure their removal and protection from direct and in-direct impacts during the construction activities.
- The removal of fauna from the site must be done in accordance with the requirements of the Nature Conservation Ordinance regulating these activities.
- Environmental corridors and “No-Go” areas must be demarcated and protected.

3.10.7 CLEARING OF VEGETATION, STRIPPING & CONSERVATION OF TOPSOIL

The contractor shall take all reasonable steps to minimise the impact of his activities on the environment. If natural vegetation have to be removed for construction purposes, the natural vegetation shall be rescued, re-used (e.g. stabilizing the area after construction or re-vegetating other impacted areas) in such a way that it enhances the remaining natural veld. By the same principle topsoil (which contains the remaining natural seed

store as well as possibly many bulb species) must be carefully removed and stored or re-used for rehabilitation or impacted areas in the immediate vicinity.

Vegetation clearing:

- A Method Statement must be submitted detailing the methods to be used for vegetation clearing.
- All cleared areas must be stabilised as soon as possible.
- Burning of cleared vegetation on site is prohibited.
- The burying of cleared vegetation or use as part of backfill or landscape shaping is prohibited unless written approval is obtained from the ECO.
- Cleared vegetation may be used for mulch or slope stabilisation of the Site.
- Should bulk vegetation be removed from the designated working areas (footprint area) then tall vegetation shall first be removed through brush cutting and chipping of larger shrub material; this may be added to the topsoil material stockpiles as mulch.
- Unless otherwise agreed upon, only indigenous plant material shall be used for this purpose.

Topsoil removal

- Prior to any activities within the demarcated work areas, topsoil material shall be removed to a depth of 300 mm or deeper if specified by the engineer in consultation with the ECO, and stockpiled in a designated area for use in rehabilitation of the site post construction. Only sufficient topsoil is to be stored for rehabilitation purposed.
- Topsoil from the still relatively natural area (the top 15 -20 cm) should be removed and be used for rehabilitation after construction on site or in the immediate vicinity of the site.
- Any area where the topsoil will be impacted by construction activities, including the construction offices and storage areas, must have the topsoil stripped and removed and covered with herbaceous vegetation (other than alien species), overlying grass and other fine organic matter and stockpiled for subsequent use in rehabilitation.
- Topsoil storage areas must be convex and should not exceed 2 m in height. The Contractor must ensure that the material does not blow or wash away. The use of a bund wall should be considered, if appropriate, for the storage of the top soil.
- The topsoil should be stored outside the 1:50 flood level within demarcated area.
- Topsoil shall be kept separate from overburden and shall not be used for building or maintenance of access roads.
- Topsoil must be treated with care, must not be buried or in any other way be rendered unsuitable for further use (e.g. by mixing with spoil) and precautions must be taken to prevent unnecessary handling and compaction.
- In particular, topsoil must not be subject to compaction greater than 1 500 kg/m² and must not be pushed by a bulldozer for more than 50 m. Trucks may not be driven over the stockpiles.
- Topsoil from different soil types must be stockpiled separately and replaced in the same areas from which they were taken if this proves to be the case. Specific attention should be given to the areas that may house rare and threatened species.
- Topsoil areas must be demarcated in order to ensure the safekeeping of topsoil and to separate different stockpile types.

3.10.8 EROSION & SEDIMENTATION CONTROL

The Contractor must take appropriate on-going and active measures to prevent erosion resulting from his own construction activities and operations as well as storm water control measures to the satisfaction of the ECO. During construction the Contractor must protect areas susceptible to erosion by installing all the necessary temporary and permanent drainage works as soon as possible.

In order to achieve erosion and sediment control, the following are applicable to all sites:

- No new development, without written authority approval, will be allowed on slopes greater than 12% (CARA, regulation 3). If applicable terraces will be made in accordance with agricultural regulations.
- Install erosion and sediment controls before work starts and maintain these features throughout the construction and operational phases (as applicable).
- Leave as much vegetation as possible.
- Install temporary fences to define “No Go” areas in those areas that are not to be disturbed.
- Divert run-off from upslope away from the site, but ensure that it does not cause downstream erosion. For example, dig drainage channels (catch drains sized to accommodate the upslope catchment).
- Install sediment controls down slope of the site to catch sediment (if applicable).
- Inspect and maintain erosion and sediment controls regularly.
- Limit vehicle movement to the site and control access points. Clearly mark such access points and inform all suppliers.
- Save and re-use topsoil during revegetation. Never store topsoil around trees as this may kill them. Spread the topsoil back when the work is finished and revegetate the site as soon as possible to control erosion. Remove the sediment and erosion controls only after revegetation was successfully implemented.
- Store all stockpiles and building materials behind sediment fences. Cover them with plastic to prevent erosion by wind.
- It is illegal to discharge water into a public stream if the quality does not conform to the required health or water standards. Other measures as may be necessary must be taken to prevent the surface water from being concentrated in streams and from scouring the slopes, banks or other areas. Any potential hazardous fluids / materials must be protected from the rain to prevent them being washed into storm water channels. All such measures must be discussed with and approved by the ECO.
- If required, build a dam below any works areas. Surround the wash-out area with a sediment fence that slows down the water flow. Filter or settle-out all water pumped off the site. The water must be clear before it enters the storm water system or creeks. Gypsum can be applied to muddy (turbid) water to help clay particles settle.
- Fill in all trenches immediately after services have been laid.
- Work must be done during the dry season, low flow conditions.
- Downstream placement of sediment containing measures.
- Due diligence to limit sediments washing down the river.
- Vegetation of ramps and shoulders.

3.10.9 ALIEN INVASIVE MANAGEMENT PLAN

In accordance with Regulation 15 and 16 of the Conservation of Agricultural Resources Act, 1983 (Act no. 43 of 1983) (CARA) as amended, all listed alien invasive plant species must be managed on any land in SA. As such an alien invasive management plan may be required to be implemented during construction and operation phase of the project. If such a plan is required, it must include mitigation measures to reduce the invasion of alien species and ensure that the removal of alien species is undertaken. Wetlands and rivers are especially susceptible to many of species.

- In accordance with CARA all identified alien invasive plants encountered on the property and its immediate surroundings must be controlled.
- All invasive alien plants must be cleared from the site and remainder of the landowner’s property).
- An invasive alien plant monitoring, eradication and control plan should be compiled to effectively remove all infestations on the property. This will allow for a degree of natural passive restoration of natural vegetation.

- All alien invasive species must be identified and removed from each site and its immediate surroundings. This is especially true for any remaining natural corridor on site.
- Any exotic trees currently growing in riparian zones on site should be cut and the stumps treated with herbicide to prevent re-growth;
- No vegetation may be buried or burned on site.
- Where the use of herbicides and other poisonous substances are to be used, the Contractor must submit a Method Statement.

The invader status of the various invasive alien species in South Africa is described in accordance with Regulation 15 and 16 of the Conservation of Agricultural Resources Act, 1983 (Act no. 43 of 1983) (CARA) as amended (the 3 categories and its control are summarised underneath).

Category 1 (Declared Weed)

- Prohibited on any land or water surface in South Africa
- Must be controlled or eradicated (except in biological control reserves).

Category 2 (Declared Invader – commercial value)

- Allowed only in demarcated areas under controlled conditions
- Outside of controlled areas invaders must be controlled or eradicated where possible
- Prohibited within 30 m off the 1:50 year flood line of watercourses or wetlands unless authorization has been obtained

Category 3 (Plant Invaders – ornamental value)

- Allowed only in areas where they were already in existence with the promulgation of the regulations.
- Prohibited within 30 m of the 1:50 year flood line of watercourses or wetlands unless authorization has been obtained.
- All reasonable steps must be taken to ensure that they do not spread.
- Propagative materials of these plants (e.g. seeds or cuttings) may no longer be planted, propagated, imported, bought, sold or traded in any way.

3.10.10 PROTECTION OF ARCHAEOLOGICAL & PALEONTOLOGICAL REMAINS

Archaeological remains are ancient man-made objects, structures, or ancient burials that have been preserved on the earth's surface, underground, or underwater and serve as the historical sources that make it possible to reconstruct the past history of human society, including mankind's prehistory. Palaeontology, on the other hand, is the study of prehistoric life. It includes the study of fossils to determine organisms' evolution and interactions with each other and their environments (their paleoecology). Palaeontology lays on the border between biology and geology, and shares with archaeology a border that is difficult to define.

- Basic archaeological remains include work tools, weapons, domestic utensils, clothing, and ornaments; settlements including campsites, fortified and unfortified settlements, and separate dwellings; ancient fortifications; the remains of ancient hydraulic structures; ancient agricultural fields; roads; mining pits and workshops; ancient burial grounds and various burial and religious structures (stelae, stone figurines, stone fish monoliths (vishaps), menhirs, cromlechs, dolmens, sanctuaries); drawings and inscriptions carved into individual stones and cliffs; and architectural monuments. Archaeological remains also include ancient ships and their cargoes that sank in rivers and seas and settlements that came to be underwater as a result of shifts in the earth's crust
- Should any archaeological remains (including but not limited to fossil bones and fossil shells, coins, indigenous and/or colonial ceramics, any articles of value or antiquity, stone artefacts and bone remains, structures and other built features, rock art and rock engravings) are discovered during construction they must immediately be reported to SAHRA and must not be disturbed further until the necessary approval has been obtained from SAHRA.

- Should any human remains/burial or archaeological material be disturbed, exposed or uncovered during construction, these should immediately be reported to the South African Heritage Resources Agency (021 462 4502). The ECO and ER are also to be informed. An archaeologist will be required to remove the remains at the expense of the developer
- Note that the Contractor may not, without a permit issued by the responsible heritage resource authority; destroy, damage, excavate, alter, deface or otherwise disturb any archaeological site or archaeological material. The latter is a criminal offence under the Heritage Resources Act.
- The Fossil Find Procedure must be implemented, should any fossil material be discovered during construction, this must be safeguarded (preferably *in situ*) and the Environmental Control Officer (ECO) should alert SAHRA so that appropriate mitigation (*e. g.* recording, sampling, or collection) can be taken by a professional palaeontologist.

3.10.11 STORAGE OF CONSTRUCTION MATERIAL & STOCKPILING

The Contractor must provide a method statement (for approval by the ECO) of the construction activities which will indicate:

- the type and quantity of material to be stored;
- whether any oil contaminated/containing equipment will be stored;
- how (including what type of vehicles will be required) it will deliver the material on site at the necessary storage area; and
- whether there is any risk of spill or runoff of any building materials or chemicals and how this is to be mitigated.
- No material is to be stored or stockpiled within any riparian zones or areas of natural vegetation. Disturbed areas, such as the cultivated fields and soccer pitch area, should be used for stockpiling.

In addition:

- The Contractor must ensure that any delivery drivers are informed of all procedures and restrictions (including "no go" areas) required to comply with the Specifications. The Contractor must ensure that these delivery drivers are supervised during off-loading, by someone with an adequate understanding of the requirements of the Specifications.
- All manufactured and/or imported material must be stored within the demarcated area, and, if so required, out of the rain. All lay down areas outside of the construction camp must be subject to the Engineer and the ECO's approval in such a way as not to cause a nuisance or environmental damage.
- All building materials are to be prepared at the batching plant, to enable the effects of cement and other substances, and the resulting effluent to be more easily managed.
- It is essential that any imported material i.e. base material for road works, building sand, bedding base sand for pipe / cable lines etc. must be screened and of which the origins must be identified prior to arriving at the receiving environment, this must be approved by the Engineer / ECO.
- Special care must be taken to prevent bringing in materials contaminated with seed of Invasive Alien Plants. Contractors shall not import construction materials such as sand, gravel or fill contaminated with seed of Invasive Alien Plants, or quarried from areas surrounded by Invasive Alien plant species such as Port Jackson or Rooikrans.
- The Contractor must negotiate appropriate space on for this purpose on an area away from natural vegetation and any wetland habitat with the ECO.
- The Contractor must ensure that all staff, contractors and subcontractors are aware of and keep material within these designated storage areas. The Construction Supervisor shall ensure that the consultant team is familiar with same.
- Contractors will not be allowed to store new construction material on the sides of the access road, or within natural vegetation or next to the existing access road.
- Stockpiling of gravel, cut, fill or any other material including spoil should only be allowed in degraded areas or areas within the development footprint.
- Any area used for stockpiling and not covered by building development must be returned to at least the state they were in before stockpiling and it must be ensured that the erosion potential of these areas is not increased.
- The Contractor must ensure that the material does not blow or wash away (especially into riparian zones) or mix with each other. If the stockpiled material is in danger of being washed or blown away, the Contractor must cover it with a suitable material, such as hessian, netting or plastic.
- Also refer to the traffic- and transportation management plans and their requirements.

3.10.12 OIL STORAGE AND MANAGEMENT

An important potential environmental impact is oil spills from any oil filled equipment and machinery that may occur during transportation, operation or storage. The following conditions shall apply:

- Vehicles must be checked for oil leaks prior to going on site
- Care should be taken to prevent any potential oil spillage during upgrading activities.
- Sufficient measures should be put in place to ensure that any potential oil spills are mitigated.
- An oil spill kit should be available on site at all times during the construction activities;
- Oil containment facilities should be provided for any oil filled equipment onsite;
- All oil spills must be reported to the ECO within 24 hours, indicating the containment and rehabilitation measures implemented.

Oil spill kits are available from:

- Drizit (021) 531 5335
- Enretech (021) 683 1858
- Pinelands Environmental Technology (021) 531 3749

3.10.13 STORING OF PETROLEUM PRODUCTS

Petroleum fuels contain harmful substances known to cause health problems and can easily have adverse effects on water quality, and the environment. Petroleum spills can move rapidly into the soil and quickly contaminate drinking water. In order to prevent pollution it is important to, use proper methods when handling, using, and storing diesel fuel, gasoline, kerosene, or other petroleum products.

The South African National Standards pertaining to the installation of a storage tank include:

- Sans 310, which requires that an aboveground storage tank be of sufficient structural strength, based on sound engineering practices, to withstand normal operations and use;
- Sans 1668, for fibre-reinforced plastic tanks for the underground storage of petroleum products;
- Sans 10089-1, which deals with the storage and distribution of petroleum products in aboveground bulk installations; and
- Sans 1535, for glass- reinforced polyester-coated steel tanks, for the underground storage of hydrocarbons and oxygenated solvents, which are intended to be buried horizontally.

Above ground fuel storage tanks

Any fuel storage proposals must be cleared by the ECO before any storage or stockpiling takes place. If the contractor proposes to install above-ground fuel storage tanks for use during the construction phase of the project, the following basic requirements must be adhered to:

- A Method Statement, explaining the method of storage and mitigation measures to prevent spillages must be submitted to the ECO and accepted prior to the installation of such a fuel storage facility (please note that storage of any dangerous goods/fuel of 30 cubic meters or more require environmental authorisation).
- The fuel tank must be placed within a completely sealed concrete bund (containment structure) which must be able to contain at least 120% of the total capacity of the fuel tank.
- The banded area should be built to be at least a third wider (on all sides) than the base of the fuel tank in order to maximise its capability to contain spillages and leakages.
- The fuel distributor must also be located within banded area to better prevent against accidental spillages during refuelling.
- In addition, drip trays are to be used during refuelling.

- All vehicles, equipment, fuel and petroleum services and containers must be maintained in a good condition that prevents leakage and possible contamination of soil or water supplies.
- Fuel storage areas must comply with general fire safety requirements.
- Fuel storage areas must be at least 100m from any watercourses.

Storing of smaller quantities of fuel or oil

Any fuel storage proposals must be cleared by the ECO before any storage or stockpiling takes place. If the contractor proposes to use only small fuel storage facilities (< 200 litres) the following basic requirements must be adhered to:

- Fuels and oils must be safely located out of harm's way from the elements and safety and fire prevention must be strictly adhered to.
- All fuel oil containers must be placed within suitable drip trays to prevent accidental spillage of oils and fuels.
- A suitable leak proof container for the storage of oiled equipment (filters, drip tray contents and oil changes etc.) must be established.
- All spills are to be recorded in the ECO diary.

3.10.14 STORING OF HAZARDOUS SUBSTANCES

If potentially hazardous substances are to be stored on site, the Contractor must submit a Method Statement detailing the substances and/or materials to be used, together with the storage, handling and disposal procedures of the materials to the ECO.

- Hazardous materials must be stored under lock and key in designated areas with properly displayed and visible warning signs.
- No works related to the submitted Method Statement may commence until the Method Statement has been studied and approved in writing.
- An effective monitoring system to detect any leakage or spillage of all hazardous substances during their transportation, handling, use and storage must be implemented. This must include precautionary measures to limit the possibility of oil and other toxic liquids from entering the soil or storm water systems.
- Measures to protect hydrological features such as streams, rivers, pans, wetlands, dams and their catchments, and other environmental sensitive areas from construction impacts including the direct or indirect spillage of pollutants must be implemented.
- **Paints:** - No paint products may be disposed of on Site and brush/roller wash facilities must be established to the satisfaction of the Engineer and the ECO. Oil based paints and chemical additives and cleaners such as thinners and turpentine must be strictly controlled. A Method Statement detailing the paint management procedures is required.
- **Hazardous building materials:** -Hazardous building materials must be identified and dealt with in accordance with the relevant safety and health legislation. All such material must be separated on Site and disposed off at appropriate licensed disposal sites. The Contractor must supply the ECO with a certificate of disposal.

3.10.15 USE OF CEMENT OR CONCRETE

The Contractor is advised that cement and concrete are highly hazardous to the natural environment because of the high pH levels of the material, and the chemicals contained therein. Wash-out water with high pH is the

number one environmental issue for the ready mix concrete industry. The alkalinity levels of wash water can be as high as pH 12, which is toxic to fish and other aquatic life.

The Site Supervisor or Contractor must indicate the need for and the proposed location of concrete batching plants which includes the location of cement stores, sand and aggregate stockpile areas. A Method Statement indicating the layout, type of concrete batching preparation (dry or wet mix). The site agent must indicate on the Method Statement proposed total volume of concrete that is needed for the completion of the entire project.

Concrete/cement mixing:

- Concrete and cement may only be mixed on existing hard surfaced areas, or edged mortar boards or a suitable container. Concrete may not be mixed or stored directly on the ground under any circumstances.
- The visible remains of the batch and concrete, either solid, or from washings, must be physically removed immediately and disposed of as hazardous waste.
- Washing of equipment shall be done in a container to prevent any runoff of contaminated washing water.
- Extreme care must be taken to limit the amount of water contaminated by washing equipment. Water from concrete washing can be re-used in concrete mixes or must be stored in drums, then removed from the site and disposed of at a licensed municipal dump site.

Concrete batching plants

The following procedures must be implemented to control waste water run-off from concrete batching plant locations:

- The location of concrete batching areas must be approved by the ECO (if possible/appropriate, the use of ready-mix concrete is preferred).
- Concrete batching facilities must have suitable bunding methods in place to ensure minimal waste water run-off occurs during batching operations.
- Contaminated water may not enter a natural or man-made (e.g. trench / sloop or dam) water system. Preventative measures include establishing sumps from where contaminated water can be either treated in situ or removed to an appropriate waste site.
- Dry mixing batching areas to be carefully placed in consultation with the ECO.
- Cement bags are to be stored securely out of harm's way from the elements (wind and rain). Bags have to be covered and placed on plastic sheeting. Used cement bags must be disposed of on a regular basis via the solid waste management system, and must not be used for any other purpose.
- Sand and stone used for cement or concrete batching must be stored on plastic layers (or on ECO approved disturbed areas) in order to prevent contamination of the natural environment.
- Cleaning of equipment and flushing of mixers must not result in pollution of the surrounding environment. All wastewater resulting from batching of concrete must be disposed of *via* the contaminated water management procedure.
- Excess or spilled concrete must be confined within the works area and all visible remains of excess concrete must be physically removed and disposed of on completion of cement work. Washing the remains into the ground is not acceptable. All excess aggregate must also be removed.
- Wash-down areas must be confined to within the concrete batching areas only.

3.10.16 FIRE FIGHTING

Adequate fire fighting equipment according to the fire hazard during the construction period must be available on site and in good working order (at least one type ABC (all purpose) minimum 4.5 kg extinguisher and 3 fire beaters per working area). The persons on site must be trained in the use of such equipment.

- The main contractor must provide a list of all authorities involved in fire fighting in the region. This list must include emergency contact numbers and must be visible at the site office.
- Welding, gas cutting or cutting of metal will only be permitted inside the working areas.
- The Contractor must pay the costs incurred to organizations called to put out any fires started by him. The Contractor must also pay any costs incurred to reinstate burnt areas as deemed necessary by the land owner.
- It is required that contractors have available the emergency telephone numbers of the nearest local Fire Fighting Station and that an emergency fire fighting re-action plan has been drawn up with on site workers and the resident land-owner / farmer.
- No on site fires are permitted.
- No firewood may be collected on site or from the surrounding natural area.

3.10.17 EMERGENCY PROCEDURES

It is the responsibility of the contractor to assess the potential risks to the environment as a result of the project. As such, the contractor must have the necessary standard emergency operating procedures in place to deal with any potential emergency such as oil spills or fire.

- All staff should be made aware of the necessary basic emergency procedures in the event of an emergency including injuries to staff. The appropriate equipment and identified personnel to deal with such basic emergencies should be available on site.
- All staff on site should wear hi-viz vests when on site.
- **Fire:** The Contractor must advise the relevant authority of a fire as soon as one starts and must not wait until he can no longer control it. The Contractor must ensure that his employees are aware of the procedure to be followed in the event of a fire.
- **Hazardous Material Spills:** The Contractor must ensure that his employees are aware of the procedure to be followed for dealing with spills and leaks, which must include notifying the Engineer, the ECO and the relevant authorities. Treatment and remediation of the spill areas must be undertaken to the reasonable satisfaction of the ECO and Local Authority.

3.10.18 SOLID WASTE MANAGEMENT

Waste refers to all solid waste, including domestic waste, hazardous waste and construction debris. The Contractor are responsible for the establishment of a refuse control system (which must consider recycling wherever possible) that is acceptable to the ECO. Disposal arrangements must be made in advance and cleared with the ECO before construction starts.

- No littering or on-site burying or dumping of any waste materials, vegetation, litter or refuse may occur.
- All solid waste must be disposed of offsite at an approved landfill site in terms of section 20 of the Environment Conservation Act (Act No. 73 of 1989). The Contractor must supply the ECO with a certificate of disposal.
- The Contractor must provide problem animal- and weatherproof bins with lids of sufficient number and capacity to store the solid waste produced on a daily basis. The lids must be kept firmly on the bins at all times. Bins must not be allowed to become overfull and must be emptied regularly.
- Waste from bins may be temporarily stored on Site in a central waste area that is weatherproof and scavenger proof and which the Engineer and the ECO has approved.

- All hazardous waste must be disposed of at a registered hazardous waste disposal site and certificates of safe disposal must be obtained.
- All waste generated during the decommissioning and reconstruction activities must be removed by the Contractor as soon as possible, and within the period specified in the EMP and disposed of at a registered landfill site.
- The Contractor must make provision for workers to clean up the Contractor's camp and working areas on a daily basis so that no litter is left lying around and so that the site is in a neat and tidy state. The Contractor must remove from site the refuse collected at least once a week.
- Waste and any excess material (and concrete slabs and pipes) should not be dumped into any riparian zones.

3.10.19 TOILETS & ABLUTION FACILITIES

The Contractor must provide suitable sanitary arrangements at designated points of the construction site for all site employees. A minimum of one toilet must be provided per 15 persons at each working area (station) or as stipulated in the Management plan.

- The toilet must be within easy reach (max 300m) of the working area and be in good working condition and cleaned on a daily basis. Toilet paper must be provided. The toilets must be emptied on a weekly basis or when full or when instructed by the ECO on site.
- Toilets should be placed at least 50m from any watercourses.
- Toilets should be adequately screened from any public areas or residences.
- Disposal arrangements must be made in advance and cleared with the ECO before construction starts. Sanitation provision and servicing must be to the satisfaction of the ECO.
- The Contractor must ensure that toilets are emptied prior to any builders' holidays, and/or weekends.
- Toilets must be of a neat construction and must be provided with doors and locks and must be secured to prevent them blowing over.
- NB: No burying of any waste material on or near the construction site nor anywhere on the surrounding property is permitted.
- Eating areas that are allocated for workers must be established in an environmentally acceptable manner and in line with all OH&Safety Act regulations. All on site and on route workers temporary eating areas must have acceptable toilet and refuse management systems in place and these areas must have suitable refuse receptacles' available for the containment and disposal of general litter and refuse.

3.10.20 DISCHARGE OF CONSTRUCTION WATER

Potential pollutants of any kind and in any form must be kept, stored, and used in such a manner that any escape can be contained and the water table not endangered. This particularly applies to water emanating from runoff from construction areas/fuel depots/workshops/truck washing areas.

- The contractor, being responsible for the construction and effective containment and maintenance of settlement ponds must ensure that the surrounding environment is not adversely affected as a result of construction activities.
- Wash down areas must be placed and constructed in such a manner so as to ensure that the surrounding areas are not polluted. Contaminated water includes water that is carrying excess sediment due to construction activities.
- Contaminated water storage facilities must not be allowed to overflow and appropriate protection from rain and flooding must be implemented.
- Contaminated water that is removed from site must be disposed of at a facility approved by the ECO and Local Authority.

- No contaminated water that does not meet the water quality standards and criteria under the National Water Act may be released into a natural system, whether it is to surface or groundwater.
- All cement effluent from mixer washings, and run-off from batching areas and other work areas must be contained in suitable sedimentation ponds.
- Sedimentation ponds must be allowed to dry out on a regular basis to allow for solid material to be removed.
- This material must be disposed of in a suitable manner, depending on the nature of the material, and to the discretion of the ECO

3.10.21 EATING FACILITIES

The Contractor must designate eating areas for the approval of the ECO, which must be clearly demarcated. No eating of meals must take place outside these designated areas without the approval of the Contractor/ESO.

- The feeding, or leaving of food for animals are strictly prohibited.
- Sufficient waste bins must be present in this area and emptied regularly.
- The contractor must supply cooking facilities that are suitable for the environment and are not liable to cause the outbreak of fires.
- The contractor must supply all construction staff with adequate clean water, and may not be sourced from surrounding farms/ landowners, unless written permission is granted by the landowner.
- No overnight camping/stay on site allowed. If overnighing is necessary for security purposes then it must be cleared with the ECO on site.
- No washing in dams or streams are allowed.

3.10.22 DUST CONTROL

The Contractor must take all reasonable measures to minimize the generation of dust as a result of construction activities resulting from along-construction-route activities (but must also take into account possible water constrictions of the area).

- The onsite construction site agent must take into account prevailing wind strength and wind direction and must have preventative measures on standby to minimize dust pollution that may cause damage to people and property.
- The liberation of dust into the surrounding environment shall be effectively controlled by the use of, inter alia, water spraying and/or other dust-allaying agents. The use of potable water should be avoided for dust control. The speed of haul trucks and other vehicles must be strictly controlled to avoid dangerous conditions, excessive dust or excessive deterioration of the road being used.
- Earth-works should be done after the harvest season, or as agreed upon by the Applicant/land-owner.

3.10.23 RESTORATION AND REHABILITATION

The Contractor must ensure that all structures, equipment, materials and facilities used or created on site for or during construction activities are removed once the project has been completed. On completion of the project or phase, all areas impacted by the construction activities must be reinstated and/or rehabilitated to the satisfaction of the ECO with emphasis on the following:

- Immediately after the demolition of the camp site or once construction has been completed, the contractor shall restore the site to its original state, paying particular attention to its appearance relative to the general landscape. This must be done as soon as possible after construction has ended to ensure

no possible environmental degradation of the site as a result of erosion, alien vegetation establishment etc.

- The contractor's procedure for rehabilitation shall be approved by the ECO and Engineer.
- Site offices must be removed and the areas rehabilitated or reinstated to the satisfaction of the ECO.
- Labourer's facilities (if applicable) must be removed and the areas rehabilitated or reinstated to the satisfaction of the ECO.
- All construction site areas must be rehabilitated or reinstated to the satisfaction of the ECO.
- All temporary fencing and demarcation must be removed and the areas reinstated to the satisfaction of the ECO.
- Temporary storage areas must be rehabilitated or reinstated to the satisfaction of the ECO.
- All remaining construction material must be removed and the areas rehabilitated or reinstated to the satisfaction of the ECO.
- The old road sections should be rehabilitated after construction to allow for regrowth of vegetation.

Any additional **disturbed** areas must be rehabilitated or reinstated to the satisfaction of the ECO. This shall include but not be limited to:

- Earthworks to reinstate the physical characteristics of the site. Here attention to the natural vertical and lateral heterogeneity in landform shall guide the reinstatement of natural areas.
- Replacement of topsoil material – care shall be taken to ensure that the same material that was removed from each area is replaced there, since this will carry the seed complement appropriate for re-establishment of each plant community type.
- Final landscaping by machine, but landscaping by hand may be required in many areas under rehabilitation.
- Re-seeding and / or replanting of rehabilitated areas.
- The Contractor shall not be permitted to use fertilisers or pesticides.
- It is imperative that any potential erosion problems are addressed. This may require subsequent site visits to monitor the efficacy of erosion control measures.

3.10.24 LAND MANAGEMENT

- Vehicles accessing the construction site must be made aware of driving in hazardous road conditions, sharp bends, narrow roads, bad weather, on or near children or domestic animals along the road.
- Vehicle movements should be kept to a minimum during rain to avoid damage to access roads.
- No fences or gates on the relevant construction property must be damaged. All access gates to the property (construction site) to be kept closed at all times to prevent domestic and or wild animals from getting out. Access by unauthorised personnel should be controlled. The access gates to the construction areas must always be closed.
- Soil erosion must be prevented at all times along the access roads and around construction areas.

3.10.25 SOCIO-CULTURAL ISSUES

- Neighbouring community, adjacent land owners and occupiers etc. must be treated with respect and courtesy at all times.
- The cultural lifestyles of the communities living in close proximity to the construction areas must be respected.
- Hours of work on the site shall be limited to normal working hours, as accepted by the local authority.
- Should construction be required outside of these times, permission is to be obtained from the local municipality, in consultation with the ECO and the surrounding landowners.

3.11 EMERGENCY PREPAREDNESS & RESPONSE

The following potential emergency situations have been identified and include the procedure for responding to, and for preventing and mitigating the environmental impacts that may be associated with them (also refer to Penalties and Fines).

3.11.1 ACCIDENTAL FIRES

Fire safety is a very real risk and must be stringently controlled. No fires will be permitted on site for any reason. If required, a designated smoking area will be provided, and clearly demarcated and signposted, with a facility for safe containment and disposal of cigarette butts.

The following measures must be implemented:

- Adequate fire fighting equipment must be available on site and in good working order (including at least one type ABC (all purpose) minimum 4.5 kg fire extinguisher and 3 fire beaters per working area). The persons on site must be trained in the use of such equipment.
- The main contractor must provide a list of all authorities involved in fire fighting in the region. This list must include emergency contact numbers and must be visible at the site office.
- The contractors must establish an emergency procedure (with contact numbers) to the satisfaction of ECO (whenever work is done in any fire prone areas).
- The contractor must adhere to the installed hydrogen facility's safety guidelines.
- The contractor must implement the applicable hydrogen facility's safety guidelines.

3.11.2 HYDROCARBON SPILLS

Since the project is in proportion relative small, no fuel storage or distribution facilities are expected to be established. As a result the significance of any spill is much reduced. The following must be observed:

- Vehicles will arrive on site already fuelled for the project.
- If additional fuel is needed, it will be brought in as needed (minimal volumes) and refuelling will be done using a pump and not a funnel (to minimize the risk of spills).
- Spill trays shall be used during re-fuelling.
- In the case of accidental spillages or leakage, the contractor will be responsible for immediate containment and corrective action (e.g. stopping the leakage), and to inform the Construction Supervisor and ECO.
- The ECO will recommend the best possible environmental solution.
- The Contractor will be liable for any costs incurred.

3.11.3 CONCRETE/CEMENT SPILLAGES

The Contractor/supplier will be liable for the safe and correct deliverance of substantial loads of concrete or cement.

- Should a spill occur the Contractor/supplier will be liable for all costs of the rehabilitation needed.

4. OPERATIONAL EMP (OEMP)

The most important part of the operational phase will be to ensure that the site is meticulously maintained and that the operations are carefully monitored. The applicant, Roma Energy Vanrhynsdorp (Pty) Ltd will remain overall responsible for the environmental performance of the site and must be aware of the legal requirements and obligations. The applicant must also be aware of the legal action that can be taken against him as a person with regards to negligence leading to environmental pollution.

The owner or delegated responsible person must implement an operational and maintenance management plan for the lodge development. This plan must include:

- Access management and control
- Water management and monitoring.
- Erosion management
- Waste and pollution management (separate the hydrogen and solar facility waste streams).
- Fire Management
- Minimise dust and air emissions
- Protection of indigenous natural vegetation and fauna
- Alien vegetation removal
- Specific monitoring and operational instructions.
- Emergency plans which will cover all reasonable aspects of the operations which might lead to environmental pollution or degradation, including the hydrogen plant.

4.1 TRAFFIC ACCESS ROUTES & HAUL ROADS

The Operator of the site must control the movement of all vehicles and plant including that of his suppliers so that they remain on designated routes. In addition such vehicles and plant must be so routed and operated as to minimise disruption to regular users of the routes not on the Site.

- On gravel or earth roads on Site, the vehicles of the Contractor and his suppliers must not exceed a speed of 25 km/h.
- On public roads adjacent to the Site vehicles will adhere to municipal and provincial traffic regulations.
- Only approved access roads may be used.
- All measures must be implemented to minimize impacts on local commuters e.g. limiting construction vehicles travelling on public roadways during the morning and late afternoon commute time and avoid using roads through densely populated built-up areas so as not to disturb existing retail and commercial operations.
- Maintenance roads should not be widened into any riparian zones.
- The collection of the hydrogen from the site must be executed by licensed trucks that adhere to the applicable norms and standards to transport hydrogen (hazardous material).

4.2 ENERGY MANAGEMENT

Even though energy supply will be derived from the Solar PV facility itself, all reasonable steps must be taken to ensure the efficient management of energy. Energy management and conservation measures must be propagated and encouraged. The objective of energy management will be to encourage the conservation of energy, for example:

- Ensure that cooling units are located and operated to conserve energy. If refrigerant are to be used, please note that R22 as a refrigerant is being phased out (due to negative impacts on the ozone layer)

and that the following gasses are more environmentally friendly options: ammonia, R134a, R143a, R404A, R407C, R410A, and R507A.

- Install energy-efficient appliances (e.g. a grade one refrigerator is at least 35% more energy-efficient than a grade three one).
- Install energy efficient lighting (which uses less energy to give the same amount of illumination and last longer than conventional incandescent bulbs).
- Insulate water heaters and hot water pipes (insulating hot water pipes from the water heater to the source are another way to conserve).
- Disconnect or switch- off units/appliances which are not in use.
- Monitor different energy uses (e.g. electricity, fuels and gas).

4.3 WATER MANAGEMENT

- Ensure that all additional water uses are correctly registered with the Department of Human Settlement, Water and Sanitation (e.g. agri-industrial use).
- Water conservation measures such as low flow taps, high pressure hoses, dual flush toilets, water wise gardens, rainwater tanks etc. must be encouraged and implemented.
- Every reasonable effort must be made to reduce the long term water demand.
- Environmental training of personnel must include water conservation awareness.
- A monthly water monitor program with the aim of ever reducing the water usage must be implemented (records must be kept).

4.4 EROSION & SEDIMENT CONTROL

Soil erosion (through wind & water) removes valuable topsoil which is the most productive part of the soil profile (containing plant nutrients, seeds and bulbs). Development disturbs and loosens soils which can easily lead to erosion. The plants and animals that depended on that soil can no longer survive, and the plants that once grew that cannot re-establish itself because the seed store is gone. Soil may then have to be brought back from elsewhere, increasing the cost of the project and the risk of importing weeds and other waste or toxic material. In accordance with the Conservation of Agricultural Resources Act, 1983 (Act No. 43 of 1983) (CARA), the aim of erosion management is to prevent any form of soil erosion through proactive thinking and prevention as well as immediate rehabilitation.

In order to achieve erosion and sediment control, the following are applicable to all properties:

- Inspect and maintain erosion and sediment controls on a regular basis and ensure that it can accommodate the upslope catchment.
- Leave as much vegetation as possible.
- Install permanent fences to define 'no go' areas in those areas that are not to be disturbed.
- Install sediment catchment controls down slope of the site to catch sediment (if applicable). This must be done as soon as possible by the Applicant and should be permanent.
- Driving off road, or over the edge of the road to avoid puddles, or obstacles, should be avoided. Obstacles should be removed to avoid vehicles from having to drive off the road surface.
- The road surface must be maintained.
- Maintain storm water management infrastructure.
- Due diligence to limit sediments washing down the river.

4.5 WASTE & POLLUTION MANAGEMENT

An integrated waste management approach based on waste minimisation (e.g. reduction, recycling, re-use and disposal) must be encouraged. Poor waste management can lead to adverse environmental impacts (e.g. odours, pollution and visual impact) as well as health risks. Sound waste management is thus non-negotiable.

- No on-site burying or dumping of any waste materials, vegetation, litter or refuse may be allowed.
- Organic waste can be disposed of, buried on-site or used as mulch.
- Domestic waste must be stored in approved containers (e.g. bins with removable lids).
- All solid waste will be disposed of at a landfill licensed in terms of section 20 of the Environment Conservation Act (Act No. 73 of 1989).
- The hydrogen facility and PV plant waste streams must not be mixed.
- No material should be disposed into any riparian zone, including organic waste.
- All possible pollution sources must be identified and all reasonable steps taken to prevent pollution or accidental spillages.
- Ensure that all concentrated potential sources of pollution are protected (bunded) in order to minimise the risk of accidental spillage or pollution. Storage tanks should be bunded in such a way to contain at least 120% of the storage tank's capacity.

4.6 MINIMISE DUST AND AIR EMISSIONS

Refer to erosion and sedimentation control paragraph 3.

4.7 MANAGEMENT OF NATURAL AREAS

The objective regarding the management of natural areas are to identify critical or conservation worthy features and to manage such areas and gardens in such a manner as to promote biodiversity and ecological processes.

- Natural areas must be managed as close to natural as possible (no interference wherever possible).
- Alien vegetation should be removed from the remaining natural areas and disturbed areas that are within or adjacent to any riparian zone and the areas should be kept clear of alien vegetation. This should be implemented as soon as possible, and the alien vegetation removal programme be in place permanently to address any new growth which may occur. The land owner is responsible for the implementation of the alien vegetation removal and control on the site and the property.
- All listed invasive alien vegetation must be removed in accordance with CARA legislation (The Conservation of Agricultural Resources Act, 1983 (Act No. 43 of 1983)) as revised.

4.8 EMERGENCY PREPAREDNESS AND RESPONSE

The following potential emergency situations have been identified and include the procedure for responding to, and for preventing and mitigating the environmental impacts that may be associated with them.

4.8.1 ACCIDENTAL FIRES

Open fires will only be allowed with approval from the landowner and/or ECO and then only under controlled circumstances and in a controlled environment. If required, a designated smoking area will be provided, and clearly demarcated and signposted, with a facility for safe containment and disposal of cigarette butts.

The following measures must be implemented:

- Adequate fire fighting equipment must be available on site and in good working order (including at least one type ABC (all purpose) minimum 4.5 kg fire extinguisher and 3 fire beaters per working area). The persons on site must be trained in the use of such equipment.
- The owner must provide a list of all authorities involved in fire fighting in the region, including neighbouring land-owners. This list must include emergency contact numbers and must be visible at the office.
- The owner must establish an emergency procedure (with contact numbers).
- The operator must adhere to the installed hydrogen facility's safety guidelines.
- The operator must implement the applicable hydrogen facility's safety guidelines.
- The operator must ensure that the hydrogen plant is inspected frequently as required to identify and prevent dangerous events.

4.9 CHEMICAL MANAGEMENT

Proper chemical management is required to minimize or eliminate the risk of environmental damage, as well as the risk of fatalities, illnesses, injuries and incidents arising from the storage, handling, transport and disposal of hazardous material.

- Compliance with the Occupational Health and Safety Act of 1983
- An emergency plan must be made to comply with section 30 (Control of emergency incidents) of the National Environmental Management Act (NEMA), No. 107 of 1997.
- In case of a spill or leak of product, such incident must be reported to all relevant authorities and the Directorate: Pollution Management in accordance with Section 30 (10) of NEMA, No. 107 of 1997.
- All staff on the site must be well trained and have the appropriate PPE in all aspects of the Occupational Health and Safety procedures pertaining to activities of the solar PV facility and hydrogen plant electrolysis facility.
- Access to chemical storage areas must be strictly restricted authorised personnel.
- Material Safety Data Sheets (MSDSs) shall be readily available on site for all chemicals and hazardous substances to be used on site. Where possible the available, MSDSs must additionally include information on ecological impacts and measures to minimise negative environmental impacts during accidental releases or escapes.
- A system shall be in place to ensure that MSDS are available to all personnel (including first-aiders and medical personnel) involved in the transportation, storage, handling, use and disposal of hazardous materials on site.
- Labelling shall be in place on all storage vessels, containers and tanks, where significant risks exist (based on a risk assessment). Labelling shall clearly identify the stored material.
- Personnel using and handling chemicals shall have received proper training for this purpose, using information available from the MSDS.
- For each site establishment, yard or other temporary chemicals storage area, a map indicating the potential sources of pollution and corresponding location of spill kits will be prepared. Spill kits will be placed at sufficient proximity in accordance with the degree of risk for spillage, and a responsible person designated for each.
- Emergency response equipment for spillage containment, fires, explosions, burns, first aid, etc. must be made available.
- Visible safety signs must be placed in areas of potential hazard, e.g. where tap water is not to be used for drinking purposes, indicating the dangers of chlorine or informing of the safety equipment to be worn when entering a certain area, etc.

4.10 HYDROGEN AND BATTERY ENERGY STORAGE SYSTEM (BESS) MANAGEMENT

Prevent contamination of soil or water resources through spills, leaks etc. from the BESS

- The battery storage system must be designed by professionals and installation must comply with all norms and standards.
- The electrolysis system and hydrogen storage containers must be designed by professionals and installation must comply with all norms and standards.
- Batteries that have reached the end of their life-cycle are to be appropriately removed, preventing any spills or contamination, and are to be appropriately transported to a licenced recycling facility or hazardous waste disposal site.
- Any hazardous materials should be stored in an appropriate manner to prevent contamination of the site.
- Any accidental spills (chemicals, fuel, oil etc) that occur must be cleaned up in an appropriate manner. Contaminated soil, material etc. will need to be appropriately disposed of at a licenced facility.

5. ENVIRONMENTAL AUDIT PROGRAMME

A Final Construction Phase Audit Report is to be undertaken 6 months post construction. This must be undertaken by a qualified Independent Environmental Auditor, and is to be submitted to the Competent Authority.

Since the development includes an operational phase, annual audits for the initial two years is recommended.

In terms of the 2014 EIA Regulations, Audit Reports must be submitted to the registered Interested & Affected Parties within 7 days of submission to the competent authority.

6. DECOMMISSIONING PHASE

The facility is expected to have a lifespan of 20+ years (i.e. with routine maintenance). The facility infrastructure would only be decommissioned and rehabilitated if it becomes outdated or inadequate, in which case the facility will normally be upgraded and not decommissioned.

It is thus considered unlikely that the facility will be decommissioned. However, it is likely that the facility may be upgraded or enlarged as part of maintenance and replacement of individual components with more appropriate technology/infrastructure available at that time.

However, should decommissioning of the site after approximately 20 years take place, then **the relevant mitigation measures contained under the Construction Phase above (Section 3) must be applied during decommissioning and therefore is not repeated in its entirety in this section, bar the following general principles:**

- Site preparation activities will include confirming the integrity of the access to the site to accommodate required equipment, preparation of the site (e.g. lay down areas, construction platform) and the mobilisation of construction equipment.
- Disassembled components will be reused, recycled, or disposed of in accordance with best practise or any relevant legislation at the time.
- Specific consideration must be given to ways to minimise waste and wastage in maintenance and the decommissioning phase of the proposed development.
- Equipment used in the plant must be recycled and re-used where possible to avoid the filling of already limited landfill space.
- Batteries must be re-used, recycled or disposed of at a licenced facility.
- As far as possible, local labour must be used for the disassembly and sorting of components for recycling.
- A final public road integrity inspection in conjunction with the provincial traffic authority must take place to ensure that roads which serviced the facility are not left in a degraded state.

7. IMPACT MANAGEMENT OUTCOMES

Impact Management Outcomes

Planning, Design and Pre-Construction					
Impact	Management Outcomes	Management Actions	Responsible Person/Party	Implementation Monitoring Method	Monitoring Frequency
Demarcation of work areas	Prevent impacts on undisturbed areas and natural vegetation	<ul style="list-style-type: none"> The site will be demarcated with appropriate dropper poles. Alternative fencing may be decided upon dependent on site requirements). Other demarcation measures can be used if approved by the ECO. Work areas and access routes must be clearly demarcated to minimise environmental impact. 	Contractor	Method Statement	Once-off
Demarcation of no-go areas	Prevent impacts on sensitive features on site, seasonal streams and natural vegetation on or adjacent to the site	<ul style="list-style-type: none"> No-Go areas will be demarcated and indicated on a site plan. Natural vegetation outside of the development area will be considered no-go areas, unless for the purpose of alien vegetation clearing. 	Contractor	Method Statement	Once-off
Site camp establishment and access roads	Prevent unnecessary impacts on natural vegetation through the establishment and operations of the site camp and access roads.	The site camp, lay down areas, and access roads must be clearly defined on a plan, taking no-go areas into consideration, as well as proximity to water resources.	Contractor	Method Statement	Once-off

Fuel Storage	Prevention of fuel spillages and contamination of the soil and/or water resources	<ul style="list-style-type: none"> • The fuel tank must be placed within a <u>completely sealed concrete bund.</u> • All fuel oil containers must be placed within suitable drip trays to prevent accidental spillage of oils and fuels. • A suitable leak proof container for the storage of oiled equipment (filters, drip tray contents and oil changes etc.) must be established. • Fuel storage areas must be at least 100m from any watercourses. 	Contractor	Method Statement	Once-off
Mandatory site equipment	Ensure the correct equipment is on site to meet environmental requirements as per the EMP	<ul style="list-style-type: none"> • Adequate fire fighting equipment must be available on site and in good working order (including at least one type ABC (all purpose) minimum 4.5 kg fire extinguisher and 3 fire beaters per working area. • Drip trays to be used during refuelling or storage of small quantities of fuel on site. • Adequate toilet and ablution facilities must be provided on site. Toilets should be placed at least 50m from any watercourses. Toilets are to be serviced and cleaned on a regular basis. • Adequate waste bins to be provided on site 	Contractor	Method Statement	Once-off
Waste Management	To prevent and minimise waste generation and contamination of the site and surrounding areas	<ul style="list-style-type: none"> • No littering or on-site burying or dumping of any waste materials, vegetation, litter or refuse may occur. • All solid waste, except for the organic waste from the removed vineyards and natural vegetation, must be disposed of offsite at an approved landfill site in terms of section 20 of the Environment Conservation Act (Act No. 73 of 1989). The Contractor must supply the ECO with a certificate of disposal. • The Contractor must provide problem animal- and weatherproof bins with lids of sufficient 	Contractor	Method Statement	Once-off

		number and capacity to store the solid waste produced on a daily basis. The lids must be kept firmly on the bins at all times. Bins must not be allowed to become overfull and must be emptied regularly.			
Fire Management	Prevent unnecessary fires which may cause damage and risk to the environment, property and human health, and adequately deal with any fires that may occur on site	<ul style="list-style-type: none"> • Adequate fire fighting equipment according to the fire hazard during the construction period must be available on site and in good working order (at least one type ABC (all purpose) minimum 4.5kg extinguisher and 3 fire beaters per working area). The persons on site must be trained in the use of such equipment. • The main contractor must provide a list of all authorities involved in fire fighting in the region. This list must include emergency contact numbers and must be visible at the site office. • No on site fires are permitted. 	Contractor	Method Statement	Once-off

Construction					
Impact	Management Outcomes	Management Actions	Responsible Person/Party	Implementation Monitoring Method	Monitoring Frequency
Topsoil removal	Topsoil to be removed (if necessary), protected and stockpiled for rehabilitation after construction	<ul style="list-style-type: none"> • Prior to any activities within the demarcated work areas, topsoil material shall be removed to a depth of 300mm or deeper if specified by the engineer in consultation with the ECO, and stockpiled in a designated area for use in rehabilitation of the site post construction. • Topsoil from the still relatively natural area (the top 15 -20 cm) should be removed and be used for rehabilitation after construction on site or in the immediate vicinity of the site. 	Contractor	Method Statement	Once-off
Stockpile Management	Avoid impacts on natural areas and watercourses from stockpiling of material, waste etc.	<ul style="list-style-type: none"> • Topsoil stockpiles to be separated from waste, building material etc. stockpiles. • Stockpile areas to be demarcated prior to construction. 	Contractor	Method Statement	Once-off
Erosion Management	Prevent erosion as a result of construction activities on site	<ul style="list-style-type: none"> • Install erosion and sediment controls before work starts and maintain these features throughout the construction and operational phases. • Leave as much vegetation as possible. • Implement the Stormwater Management Plan. Adherence to the EMP & Implementation of Standard Management Procedures in terms of erosion and sedimentation. 	Contractor	Method Statement	Continually during construction
Cement mixing	Prevent contamination from cement mixing and cement waste water on	<ul style="list-style-type: none"> • Concrete and cement may only be mixed on existing hard surfaced areas, or edged mortar boards or a suitable container. 	Contractor	Method Statement	Continually during construction

	<p>the natural environment, particularly water resources. Due to the high alkaline pH of cement, it is highly hazardous to the natural environment</p>	<ul style="list-style-type: none"> • The visible remains of the batch and concrete, either solid, or from washings, must be physically removed immediately and disposed of as hazardous waste. • Washing of equipment shall be done in a container to prevent any runoff of contaminated washing water. • Extreme care must be taken to limit the amount of water contaminated by washing equipment. Water from concrete washing can be re-used in concrete mixes or must be stored in drums, then removed from the site and disposed of at a licensed municipal dump site. • Concrete batching facilities must have suitable bunding methods in place to ensure minimal waste water run-off occurs during batching operations. • Cleaning of equipment and flushing of mixers must not result in pollution of the surrounding environment. All wastewater resulting from batching of concrete must be disposed of <i>via</i> the contaminated water management procedure. 			
<p>Dust Control</p>	<p>Prevent and minimise dust generation on site which can become a nuisance to neighbouring land owners and residents, as well as being a health risk</p>	<ul style="list-style-type: none"> • The Contractor must take all reasonable measures to minimize the generation of dust as a result of construction activities resulting from along-construction-route activities (but must also take into account possible water constrictions of the area). • The onsite construction site agent must take into account prevailing wind strength and wind direction and must have preventative measures on standby to minimize dust pollution that may cause damage to people and property. • The liberation of dust into the surrounding environment shall be effectively controlled by 	<p>Contractor</p>	<p>Method Statement</p>	<p>Continually during construction</p>

		the use of, inter alia, water spraying and/or other dust-allaying agents. The speed of haul trucks and other vehicles must be strictly controlled to avoid dangerous conditions, excessive dust or excessive deterioration of the road being used.			
--	--	--	--	--	--

Rehabilitation

Impact	Management Outcomes	Management Actions	Responsible Person/Party	Monitoring Method	Monitoring Frequency
Rehabilitation of the Construction site	Rehabilitation of areas impacted by construction activities	<ul style="list-style-type: none"> • All structures, equipment, materials and facilities used or created on site for or during construction activities are removed once the project has been completed. On completion of the project or phase, all areas impacted by the construction activities must be reinstated and/or rehabilitated to the satisfaction of the ECO. • Immediately after the demolition of the camp site or once construction has been completed, the contractor shall restore the site to its original state, paying particular attention to its appearance relative to the general landscape. This must be done as soon as possible after construction has ended to ensure no possible environmental degradation of the site as a result of erosion, alien vegetation establishment etc. • The contractor's procedure for rehabilitation shall be approved by the ECO and Engineer. • Site offices must be removed and the areas rehabilitated or reinstated to the satisfaction of the ECO. • Earthworks to reinstate the physical characteristics of the site. Here attention to the natural vertical and lateral heterogeneity in landform shall guide the reinstatement of natural areas. • Replacement of topsoil material – care shall be taken to ensure that the same material that was removed from each area is replaced there, since this will carry the seed complement appropriate for re-establishment of each plant community type. 	Contractor	Method Statement	Once-off

		<ul style="list-style-type: none">• Final landscaping by machine, but landscaping by hand may be required in many areas under rehabilitation.			
--	--	---	--	--	--

Operation

Impact	Management Outcomes	Management Actions	Responsible Person/Party	Monitoring Method	Monitoring Frequency
Erosion Management	Avoid valuable topsoil removal	<ul style="list-style-type: none"> • Inspect and maintain erosion and sediment controls on a regular basis and ensure that it can accommodate the upslope catchment. • Leave as much vegetation as possible. • Install permanent fences to define 'no go' areas in those areas that are not to be disturbed. • Install sediment catchment controls down slope of the site to catch sediment (if applicable). This must be done as soon as possible by the Applicant and should be permanent. • Avoid driving off road, or off the road surface, to avoid puddles or obstacles. • During the operational phase of these gravel roads, prone to erosion exacerbated by heavy rainfall, running water must be deviated from the roads with appropriate storm water management infrastructure. Next to the road shoulders, paved swales will probably be necessary to prevent running storm water to erode deep trenches. 	Owner	Visual monitoring	Weekly/after major rain events
Waste and Pollution Management	Avoid contamination of soil and water resources with pollutants.	<ul style="list-style-type: none"> • No on-site burying or dumping of any waste materials, vegetation, litter or refuse may be allowed. • Organic waste can be disposed of, buried on-site or used as mulch. • Domestic waste must be stored in approved containers (e.g. bins with removable lids). • All solid waste will be disposed of at a landfill licensed in terms of section 20 of the 	Owner	Visual monitoring	Daily - Weekly

		<p>Environment Conservation Act (Act No. 73 of 1989).</p> <ul style="list-style-type: none"> No material should be disposed into any riparian zone, including organic waste. All possible pollution sources must be identified and all reasonable steps taken to prevent pollution or accidental spillages. 			
Emergency Preparedness - Fire	Prevent unnecessary fires which may cause damage and risk to the environment, property and human health, and adequately deal with any fires that may occur on site	<ul style="list-style-type: none"> Adequate fire fighting equipment must be available on site and in good working order (including at least one type ABC (all purpose) minimum 4.5 kg fire extinguisher and 3 fire beaters per working area). The persons on site must be trained in the use of such equipment. The owner must provide a list of all authorities involved in fire fighting in the region, including neighbouring land-owners. This list must include emergency contact numbers and must be visible at the office. The owner must establish an emergency procedure (with contact numbers). 	Owner	Visual monitoring	Daily- weekly
Hydrogen electrolysis and Battery Energy Storage Systems (BESS)	Prevent contamination of soil or water resources through spills, leaks etc. from the BESS	<ul style="list-style-type: none"> The hydrogen electrolysis facility and battery storage system must be designed by professionals and installation must comply with all norms and standards. Batteries that have reached the end of their life-cycle are to be appropriately removed, preventing any spills or contamination, and are to be appropriately transported to a licenced recycling facility or hazardous waste disposal site. Any hazardous materials should be stored in an appropriate manner to prevent contamination of the site. Any accidental spills (chemicals, fuel, oil etc) that occur must be cleaned up in an 	Owner	Visual monitoring	Daily - weekly

		appropriate manner. Contaminated soil, material etc. will need to be appropriately disposed of at a licenced facility.			
Management of Natural Areas	Prevent impacts on, and loss of, adjacent natural vegetation	<ul style="list-style-type: none"> Natural areas must be managed as close to natural as possible (no interference wherever possible). Alien vegetation should be removed from the remaining natural areas and disturbed areas that are within or adjacent to any riparian zone and the areas should be kept clear of alien vegetation. This should be implemented as soon as possible, and the alien vegetation removal programme be in place permanently to address any new growth which may occur. Land owner is responsible for the implementation of the alien vegetation removal and control on the site and the property. All listed invasive alien vegetation must be removed in accordance with CARA legislation (The Conservation of Agricultural Resources Act, 1983 (Act No. 43 of 1983)) as revised. 	Owner	Visual monitoring	Weekly

APPENDIX 1: ENVIRONMENTAL AUTHORISATION

To be included on approval (before construction begins).

APPENDIX 2: Maps & Drawings

Site Development Plan including No-go areas and buffers

APPENDIX 3: START-UP REPORT

To be included after start-up meeting.

APPENDIX 4: PENALTIES FOR NON-COMPLIANCE

PENALTIES FOR NON-COMPLIANCE

The contractors / sub-contractors must contact the ECO at any stage if unsure about any matter, or if a pollution incident occurs, or vegetation or animals are damaged.

ECO = Environmental Control Officer ESO= Environmental Site Officer

PHASE	Penalty for Non-compliance	
	Bottom range	Top Range*
PRE-CONSTRUCTION PHASE		
Construction area to be marked off before construction starts.		5000
The demarcated area must be maintained throughout the construction phase	500	1000
Site area for stock piling of building material must be demarcated	500	5000
Site area for storing of waste material must be demarcated	500	5000
Fencing off the construction site with mesh fencing of 1.8m, where necessary or other suitable material as agreed on by ECO	500	1000
Sitting of access road/s to be approved by ECO & demarcated with stakes before any construction starts (if applicable)		5000
Temporary route used for construction must be determined on site with ECO (if applicable)	1000	5000
Telecommunications & AC power routes must be determined with the ECO (if applicable)	1000	5000
Sensitive features that may be harmed must be clearly marked or demarcated.	500	2000
Vegetation that may not be removed must be clearly marked or demarcated.	500	5000
Contractor must make the Construction team and all sub-contractors aware of all environmental aspects that could lead to imposition of penalties	100	5000
Contractor to sign Declaration of understanding (DOU) before construction starts		5000
Contractor to assure that all subcontractors be informed and signed DOU	1000	5000
Method statements must be provided on request by the ECO. No work may commence until the Method Statement is accepted by the ECO and Engineer	1000	5000
CONSTRUCTION PHASE		
Information		
A copy of the EMP & Record of Decision with all the conditions of approval, and the relevant Method Statements must be at site at all times.	200	5000
Construction crew behaviour		

Construction crews may not overnight on site.	200	5000
No amplified music allowed on site	100	200
Construction crew must stay within the demarcated construction area. (Applicable in sensitive sites)	50	500
Eating of meals only allowed in demarcated area	50	500
No pets permitted on site		100
Driving, Parking & Storing of machinery and vehicles are only allowed inside demarcated areas and existing roads	1000	5000
Machinery may only be used on the road and may not disturb the vegetation on the sides of the road except if cleared by ECO. Machinery used must be carefully considered to limit environmental damage	500	5000
No vegetation other than that agreed on may be damaged - i.e. no access to areas outside construction area.	500	2000
No individual may cause unnecessary damage to flora and fauna on, around or near the site	20	2000
No littering allowed (incl. cigarette butts)	50	500
Excavations		
No topsoil may be removed or altered outside the demarcated area and/or which was not specified.		2000
Commercial sources of sand, rock and gravel to be cleared with ECO	200	5000
All surplus material to be taken off-site and be disposed of at approved site	500	5000
Toilets		
Sufficient ablution facilities must be provided		3000
Toilets to be secured to prevent them from falling or blowing over.	100	1000
They must be serviced regularly, (according to the manufacturer's instructions) and kept clean.	100	1000
Everybody on site must make use of ablution facilities	50	1000
Fire Prevention		
All mandatory fire fighting equipment (as specified at start-up) must be on site at all times	500	4000
Fire fighting equipment to be in good working order and serviced.	500	2000
No fires, including cooking fires, allowed on site	1000	5000
Cement		

Concrete may only be mixed within the boundaries of the demarcated area and/or where was agreed on by the ECO.	500	5000
All excess cement & concrete mixes to be contained on construction site prior to disposal off site	200	5000
Any cement / concrete spillage to be cleaned up immediately.	500	5000
Ready-mix delivery trucks must not carry out the wash down of their trucks on or around the site unless arranged with ECO.	1000	3000
Dust pollution control		
Ensure that loose building material is covered to prevent dust pollution	100	1000
Water run-off		
Contamination of water bodies, rivers, dams or wetlands must be prevented at all cost	500	5000
Rainwater from construction & building site/s must be channelled, contained & allowed to dry out, so as not to transport any pollutants into the surrounding area. Temporary trenches, straw stabilising, brush cutting can be used	500	5000
Waste control		
Sufficient refuse bins must be placed on site	500	2000
Refuse bins must be cleaned on a regular basis	100	1000
General litter / building refuse must be cleaned up on a regular basis from the site	500	3000
Cement-contaminated water; paint; oil; cement slurries etc must be stored in watertight containers or as agreed with ECO	500	5000
Store all refuse & waste material in wind & animal proof containers	100	1000
Waste must be disposed of at an official waste deposit site on a regular basis.	500	5000
The absence of or inadequate drip trays or bunding facilities	500	5000
Failure to address oil/fuel leaks from on-site machinery	200	5000
Herbicides		
No herbicides or pesticides whatsoever may be used.	200	2000
Construction road		
Road must be upgraded to prevent degradation and erosion of the road and surrounds.	500	5000
Power and Telecommunications supply		
Demarcate power supply route	500	5000

No vehicles to drive through vegetation unless authorised by ECO	500	5000
Storage of equipment may only take place at an area demarcated by the ECO.	500	5000
Working must be done in phases to prevent trampling of vegetation	N/A	
Use of generators and fuel powered equipment		
A watertight cover must be place under the power generator equipment to prevent accidental spillage of fuel & oil seeping into the soil.	500	5000
Drip tray must be able to take 120% of fuel on site	500	5000
All waste material generated from the use of this equipment must be contained and removed from the site	500	5000
Mobile fuel powered equipment must be well maintained and must not have any fuel or oil leaks.	200	5000
Soil Stabilisation		
Ensure that soil material for filling and stabilisation comes from a source that does not contain seeds alien to the area. The source must be cleared with the ECO.	100	2000
Rehabilitation		
Remove rocks and stones and stock pile in area recommended by ECO	500	5000
Remove all plants that can be used for rehabilitation and store on- or off-site in appropriate manner as agreed with ECO	200	5000
Removal of all old concrete and alien materials from site	500	5000
Site must be cleared of all waste and building material	500	5000

*(Large scale / repeated offence)

APPENDIX 5: INFO ON METHOD STATEMENTS

INFORMATION ON METHOD STATEMENT

Method Statements are to be completed by the person undertaking the work (i.e. the Contractor). The Method Statement will enable the potential negative environmental impacts associated with the proposed activity to be assessed.

The Method Statement can only be implemented once approved by the ECO

The Contractor (and, where relevant, any sub-contractors) must also sign the Method Statement, thereby indicating that the works will be carried out according to the methodology contained in the approved Method Statement.

The ECO will use the Method Statement to audit compliance by the Contractor with the requirements of the approved Method Statement.

Changes to the way the works are to be carried out must be reflected by amendments to the original approved Method Statement; amendments require the signature of the ECO denoting that the changed methodology or works are necessary for the successful completion of the works, and are environmentally acceptable. The Contractor will also be required to sign the amended Method Statement thereby committing him/herself to the amended Method Statement.

This Method Statement **MUST** contain sufficient information and detail to enable the ECO to apply their minds to the potential impacts of the works on the environment. The Contractor will also need to thoroughly understand what is required of him/her in order to undertake the works.

THE TIME TAKEN TO PROVIDE A THOROUGH, DETAILED METHOD STATEMENT IS TIME WELL SPENT. INSUFFICIENT DETAIL WILL RESULT IN DELAYS TO THE WORKS WHILE THE METHOD STATEMENT IS REWRITTEN TO THE ER'S AND ESO'S SATISFACTION.

The page overleaf provides a *pro forma* method statement sheet, which needs to be completed for each activity requiring a method statement in terms of the EMP.

APPENDIX 6: EXAMPLE OF METHOD STATEMENT

PRO-FORMA METHOD STATEMENT

CONTRACT:..... **DATE:**.....

PROPOSED ACTIVITY (give title of method statement and reference number):

WHAT WORK IS TO BE UNDERTAKEN (give a brief description of the works):

WHERE ARE THE WORKS TO BE UNDERTAKEN (where possible, provide an annotated plan and a full description of the extent of the works):

START AND END DATE OF THE WORKS FOR WHICH THE METHOD STATEMENT IS REQUIRED:

Start Date:

End Date:

HOW ARE THE WORKS TO BE UNDERTAKEN (provide as much detail as possible, including annotated maps and plans where possible):

Note: please attach extra pages if more space is required

DECLARATIONS

1) ENVIRONMENTAL CONSULTANT AND/OR ENVIRONMENTAL CONTROL OFFICER

The work described in this Method Statement, if carried out according to the methodology described, is satisfactorily mitigated to prevent avoidable environmental harm:

(Signed) (Print name)

(Signed) (Print name)

Dated: _____

2) PERSON UNDERTAKING THE WORKS

I understand the contents of this Method Statement and the scope of the works required of me. I further understand that this Method Statement may be amended on application to other signatories and that the ESO will audit my compliance with the contents of this Method Statement

(Signed) (Print name)

Dated: _____

3) THE APPLICANT

The works described in this Method Statement are approved.

(Signed) (Print name) (Designation)

Dated: _____

APPENDIX 7: CONTACTOR ENVIRONMENTAL CHECKLIST

CONTACTOR/S REPRESENTATIVE: ENVIRONMENTAL WEEKLY CHECKLIST

SITE: _____

PHASE OF WORK AND % OF COMPLETION: _____

ENVIRONMENTAL ASPECT	YES/ NO (✓ or X)	COMMENTS
How many workers are on site		
All new personnel on site are aware of the contents of the EMP and have been through the environmental awareness course.		
Contractor's camp is neat and tidy and the labourers' facilities are of an acceptable standard.		
Sufficient and appropriate fire fighting equipment is visible and readily available.		
Waste control and removal system is being maintained.		
Refuse bins in place and maintained		
Toilets are in place and clean		
Demarcation and other fences are being maintained.		
What machinery are on site		
Drip trays are being utilised where there is a risk of incidental spillage		
Bunds/ drip trays are being emptied on a regular basis (especially after rain).		
No leakages (oil & fuel) are visible from construction vehicles		
No go areas, remaining natural features and trees have not been damaged.		
Dust control measures (if necessary) are in place and are effectively controlling dust.		
Noise Control measures (if necessary) is in place and is working effectively.		
Erosion control measures (if necessary) are in place and are effective in controlling erosion. (Access road, site areas etc.)		
Stockpiles are located within the boundary of the site, do not exceed 2 m in height and are protected from erosion.		

Completed by:..... Sign:..... Date:.....

To be submitted at the end of each week to the Environmental Site Officer (ESO)

Received by:

Environmental Site Officer: :..... Sign:

Date:.....

APPENDIX 8: BASIC RULES OF CONDUCT

BASIC RULES OF CONDUCT

The following list represents the basic Do's and Don'ts towards environmental awareness, which all participants in this project must consider whilst carrying out their tasks. These are not exhaustive and serve as a quick reference aid.

NOTE: ALL new site personnel must attend an environmental awareness presentation. Please inform your foreman or manager if you have not attended such a presentation or contact the ESO.

DO:

- Use the toilet facilities provided – report dirty or full facilities
- Clear your work areas of litter and building rubbish at the end of each day – use the waste bins provided and ensure that litter will not blow away.
- Report all fuel or oil spills immediately & stop the spill continuing.
- Dispose of cigarettes and matches carefully. (Littering is an offence.)
- Confine work and storage of equipment to within the immediate work area.
- Use all safety equipment and comply with all safety procedures.
- Prevent contamination or pollution of streams and water channels.
- Ensure a working fire extinguisher is immediately at hand if any “hot work” is undertaken e.g. welding, grinding, gas cutting etc.
- Report any injury of an animal.
- Drive on designated routes only.
- Prevent excessive dust and noise.

Do not:

- Remove or damage vegetation without direct instruction.
- Make any fires.
- Injure, trap, feed or harm any animals – this includes birds, frogs, snakes, lizards etc.
- Enter any fenced off or marked area.
- Allow cement or cement bags to blow around.
- Speed or drive recklessly
- Allow waste, litter, oils or foreign materials into the stream
- Swim in the dam.
- Litter or leave food laying around

Notes:

If any animals such as tortoises, chameleons or snakes be encountered then do not harm them. The ECO or Site Supervisor must be contacted to remove these safely. The harming of any animal will result in disciplinary action.

Construction and heavy machine operators must be particularly sensitive to staying within access routes and prevention of unnecessary damage. Dust and noise is also of particular concern. Ensure that vehicles and machinery do not leak fuel or oils. Refuelling or maintenance must be done within the maintenance camp area only.

Alien plant clearing and control work teams must be closely supervised.

BASIESE GEDRAGSKODES

Die volgende lys verteenwoordig die moets en moenies vir omgewingsbewustheid wat alle deelnemers aan hierdie projek in ag moet neem tydens die uitvoer van hul take. Hierdie lys is nie volledig nie en dien slegs as 'n vinnige verwysing.

Nota: alle nuwe terreinpersoneel moet 'n aanbieding ten opsigte van omgewingsbewustheid bywoon. Indien u nog nie so 'n aanbieding bygewoon het nie, lig asseblief u voorman of bestuurder in of kontak die omgewings terreinbeampte.

Moets:

- Gebruik die beskikbare toilet-geriewe – rapporteer vuil of vol geriewe.
- Maak u werkplek skoon van rommel of bourommel aan die einde van elke dag – gebruik beskikbare vullisdromme en verseker dat rommel nie rondwaai nie.
- Rapporteer alle brandstof- en olie stortings onmiddellik – stop verdere storting.
- Wees versigtig met die wegdoen van sigarette en vuurhoutjies. (rommelstrooi is 'n oortreding.)
- Beperk werkaktiwiteite en die stoor van toerusting tot die onmiddellike werkarea.
- Gebruik veiligheidstoerusting en voldoen aan alle veiligheids-maatreëls.
- Voorkom besoedeling van strome en waterbane
- Verseker dat 'n brandblusser in werkende toestand byderhand is wanneer “warm” werk verrig word bv. Sweis, wegslyp, gasny, ens.
- Rapporteer beseerde diere.
- Ry slegs op aangewese roetes.
- Voorkom oormatige stof en geraas.

Moenie:

- Plantegroei verwyder of beskadig sonder direkte instruksie nie.
- Enige vure maak nie.
- Enige diere dood, beseer, vang of voer nie, insluitende voëls, paddas, slange, akkedisse, ens.
- Enige omheinde of afgesperde areas binnetree nie.
- Sement of sementsakke laat rondwaai nie.
- Vinnig of roekeloos bestuur nie.
- Enige rommel, afval, olie or enige vreemde materiaal in strome laat beland nie.
- In die dam swem nie.
- Rommelstrooi of kos laat rondlê nie.

Notas:

Indien enige diere soos skilpaaie, verkleurmannetjies of slange teëgekomp word, moet hulle nie beseer of dood nie. Kontak die otb of ri om hulle veilig te verwyder. Die besering van diere sal lei tot dissiplinêre optrede.

Operateurs van konstruksie- en swaar masjiene moet veral versigtig wees om binne toegangsroetes te bly en om enige onnodige skade te voorkom. Verseker dat voertuie en masjiene nie olie of brandstof lek nie. Brandstofaanvulling en voertuigonderhoud mag slegs binne die onderhoudsarea gedoen word.

Streng toesig moet gehou word oor indringerplantbeheerspanne.

EZIPPHAMBILI EKUNYANZELEKILEYO UKUBA ZENZIWE

Zonke ezi zinto zilandelayo zizinto ekufuneka zenziwe nekufuneka zingenziwanga.

Wonke umntu ofikayo kufuneka afundiswe ngemigaqo kupala. Needa yazisa iforman yakho ikuba awukhange uye kufundiswa.

Izinto emazenziwe

- Sebenzisa izindlu zangasese, yazisa xa kukho umonakalo.
- Zama ukucoca apho ubusebenza khona.
- Sebenzisa imigqomo yenkukuma ungayeki iphaphtieke.
- Yazisa xa ubona ioil echithskalayo okanye ipetrol.
- Cima lozoli cigarette xa ugqibibile ukutshaya
- Zonke izixhobo usebenza zibuyisele apho zihlaka khona xa ucgibile apho zihlala khona xa ugqibile ukuzisebenzisa.
- Zisebenzise izikhuselixa uzinkiwe.
- Sukugalela izinto emlanjeni.
- Masibekho isicima mlilo xa usebenza ngomlilo.
- Yazisa msinyane xa ubone isilwanyana ezonzakeleyo.
- Xauqhuba isithuthi hamba endleleni qha ungafathulinje.
- Naphina zamaungenzi thuli okanye ingxolo xa usebenza.

Emazingenziwa

- Sukususa nesiphina isityalo ungakhange uxelelwe
- Sukwenza mlilo nokuba sekubanda
- Amagqara ukubulala izilwanyana nokuzifida akuvumelekanga
- Sukungena xa kuvaliwe ngaphandle kwe mvume
- Ingxowa zesamente mazincedwe zingahlwa nje
- Sukuqhuba ngesantya esiphakamileyo
- Sukugalele nayiphi into phaya emlanjeni
- Sukuqubha edameni q oqosha yonk inkukuma

APPENDIX 9: ECO/ESO REPORT/CHECKLIST

ECO / ESO SITE VISIT CHECKLIST / REPORT:

PROJECT NAME: DATE

PROJECT & PHASE: LOCATION

ENVIRONMENTAL ASPECT	RATING	REMARKS
Note: 1 = Poor, 2 = Average, 3 = Good NA = Not Applicable		
DEMARCATION METHOD STATEMENT Boundaries of “no go” areas, construction sites, offices, temporary storage areas as well as labourer’s facilities must be demarcated (EMP and ECO requirements) and maintained for the length of the construction period.		
NO-GO AREAS/PROTECTION OF FAUNA & FLORA Identified “No-Go Areas“, remaining natural veld and indigenous- or significant trees are protected features and must be demarcated for protection from construction damage (including secondary impact). All areas outside of the demarcated construction sites and access roads to be regarded as NO-GO areas unless otherwise agreed upon with the client and ECO. All flora identified to be rescued must be removed and placed in an area specifically allocated and taken care off until re-used in pre-approved way. Identified areas with significant vegetation must be protected as NO-GO areas.		
CLEARING OF VEGETATION & TOPSOIL REMOVAL METHOD STATEMENT Before any construction or earthworks, topsoil must be stripped (>150mm) and stockpiled for rehabilitation/ landscaping. Stockpiles: must be protected (may not blow or wash away or gets compacted) and stored separately. may not be moved further than 50m or mixed with any other soil. must be convex and should not exceed 2m in height. In addition: Cleared areas must be stabilized. Burning or burying of cleared vegetation is prohibited, but may be used for mulch or slope stabilisation on site.		
STOCKPILING METHOD STATEMENT Top- and subsoil’s from trenches must be located within site boundaries, stabilised and may not exceed 2m in height.		
TEMPORARY STORAGE FACILITIES METHOD STATEMENT Must be demarcated, organised, neat and tidy and of acceptable standards.		
CONSTRUCTION CAMP & SITE OFFICES METHOD STATEMENT Must be demarcated, organised and free of day-to-day litter (maintaining good housekeeping standards).		

ENVIRONMENTAL ASPECT		RISKS
Note: 1 = Poor, 2 = Average, 3 = Good NA = Not Applicable		
FUEL STORAGE METHOD STATEMENT Fuel storage areas must be situated within the demarcated construction camp site (or an area approved by the ECO). Bunds must be built (EMP and ECO requirements) around larger fuel storage areas (accidental spillages). Drip trays must be used (in accordance with EMP) at all fuel and oil storage and refilling sites and must be cleaned regularly, especially after rain.		
LABOURER'S FACILITIES METHOD STATEMENT Facilities must be of acceptable standards suitably demarcated, well maintained, neat and tidy and with adequate ablution facilities.		
ENTRANCE AND HAUL ROADS METHOD STATEMENT Only approved entrance and haul roads may be used (existing roads and infrastructure). No new roads or parking areas may be developed without written approval from the ECO.		
MANDATORY SITE EQUIPMENT METHOD STATEMENT Mandatory site equipment must be in place, well maintained and in accordance with EMP and ECO requirements. Sufficient refuse bins must be on site (well placed and conspicuous) and must be cleaned regularly. Fire extinguishers must be readily available, maintained and functional. Drip trays must be used (in accordance with EMP) at all fuel and oil storage and refilling sites and must be cleaned regularly, especially after rain. Toilets and sanitation facilities must be kept clean neat and hygienic (toilet paper must be available).		
WASTE CONTROL METHOD STATEMENT The contractor is expected to control all construction related waste material and general litter on actual construction sites and its immediate surroundings. Waste management must be in accordance with the EMP, of acceptable standards, with regular removal of general waste, hazardous waste as well as construction waste (e.g. concrete waste and spoil).		
CEMENT MIXING & BATCHING AREAS METHOD STATEMENT Mixing areas must be approved by the ECO, suitably demarcated and may not result in pollution. Polluted cement water may only be released into sedimentation ponds. Sedimentation ponds must be maintained and cleaned regularly (and reinstated after use).		

ENVIRONMENTAL ASPECT	RISKS	
Note: 1 = Poor, 2 = Average, 3 = Good NA = Not Applicable		
<p>CONSTRUCTION VEHICLE MAINTENANCE METHOD STATEMENT Construction vehicles must be in good working order and well maintained to prevent oil and fuel leakages and to reduce noise levels. Maintenance areas must be approved by ECO. Refuelling must be done in accordance with the EMP, using drip trays.</p>		
<p>HEAVY EARTHMOVING EQUIPMENT Construction vehicles and equipment may only operate <u>within</u> the demarcated site boundaries (and approved access roads), especially heavy earthmoving vehicles.</p>		
<p>DUST CONTROL METHOD STATEMENT Adequate control measures must be in place to prevent dust pollution as a result of construction activities (especially with regard to entrance-, haul roads and exposed surfaces). Areas of concern must be watered regularly during construction AND periods of strong winds, BUT must take water saving into account.</p>		
<p>EROSION CONTROL METHOD STATEMENT Erosion resulting from works must be controlled. Temporary and permanent drainage works must be maintained. Erosion damage and damage in drainage courses must be reinstated.</p>		
<p>NOISE CONTROL METHOD STATEMENT Effective noise control measures must be in place and acceptable working hours must be kept (deviations must be approval by the ECO).</p>		
<p>ENVIRONMENTAL CONDUCT Environmental conduct of construction personnel must be acceptable (e.g. no burning or burying of refuse; no littering and no cement bags or other construction waste material lying around).</p>		
<p>ARCHAEOLOGICAL & HERITAGE FINDS METHOD STATEMENT Should any archaeological or heritage remains be exposed during excavations or any activity on site, these must immediately reported to The site agent/engineer, the ECO or SAHRA.</p>		
<p>REHABILITATION METHOD STATEMENT On completion of the project or phase, all areas impacted by the construction activities must be reinstated and/or rehabilitated to the satisfaction of the ECO with emphasis on the following: Site offices must be removed and the areas rehabilitated or reinstated to the satisfaction of the ECO. Labourer's facilities must be removed and the areas rehabilitated or reinstated to the satisfaction of the ECO.</p>		

ENVIRONMENTAL ASPECT		POINTS
Note: 1 = Poor, 2 = Average, 3 = Good NA = Not Applicable		
<p>All construction site areas must be rehabilitated or reinstated to the satisfaction of the ECO.</p> <p>All temporary fencing and demarcation must be removed and the areas reinstated to the satisfaction of the ECO.</p> <p>Temporary storage areas must be rehabilitated or reinstated to the satisfaction of the ECO.</p> <p>All remaining construction material must be removed and the areas rehabilitated or reinstated to the satisfaction of the ECO.</p> <p>Any additional disturbed areas must be rehabilitated or reinstated to the satisfaction of the ECO.</p>		
<p>ADDITIONAL METHOD STATEMENTS</p> <p>Method statements must be submitted and approved before commencement of the works and must be available at the site offices.</p>		
<p>ENVIRONMENTAL CHECKLIST</p> <p>The contractor must ensure that the weekly environmental checklist is completed at the end of each week and it must be available at the site offices.</p>		
<p>SPOT FINES & PENALTIES</p> <p>Spot fines and penalties must be recorded and documented by the ECO (in accordance with the EMP).</p>		
<p>FIXED POINT PHOTOS</p> <p>Photographs must be taken by the ECO, Site Engineer and or Site Manager, prior to, during and immediately after construction as visual reference. These photographs must be stored with other records relating to the EMP.</p>		

ECO:

APPENDIX 10: METHOD STATEMENT REGISTER

METHOD STATEMENT REGISTER		Principle Site Agent:				Project Name:	
		Main Contractor:				Project location:	
No.	METHOD STATEMENT ACTIVITY REFERENCE	DATE CREATED	DATE RECEIVED	CREATED BY	ACCEPTED / REJECTED	DATE approved	Approved By
1	Demarcation						
2	Clearing of vegetation and topsoil removal						
3	Stockpiling						
4	Temporary storage facilities						
5	Construction camp and site offices						
6	Fuel storage						
7	Labourer's facilities						
8	Entrance and haul roads						
9	Mandatory site equipment						
10	Waste management/control						
11	Cement mixing and batching areas						
12	Construction vehicle maintenance						
13	Dust control						
14	Erosion control						
15	Noise control						
16	Archaeological and heritage finds						
17	Rehabilitation						
18							
19	<u>Additional MS (Waste Licence requirements)</u>						
20							
21							
22							

APPENDIX 11: ENVIROMENTAL INCIDENT REPORT FORM

ENVIRONMENTAL INCIDENT REPORT

PROJECT NAME:	_____
PROJECT LOCATION:	_____
SITE AGENT:	_____
DATE OF INCIDENT:	_____ TIME: _____

BRIEF DESCRIPTION AND CAUSE OF INCIDENT:

WHAT IMMEDIATE ACTIONS/CONTROL MEASURES WERE TAKEN:

WHAT CORRECTIVE ACTIONS WERE TAKEN TO ENSURE NO REPEATS OF THE INCIDENT:

ECO/ESO RESPONSE TO INCIDENT AND RECOMMENDATIONS:

IS THIS INCIDENT A: **FIRST OFFENCE** **SECOND OFFENCE** **THIRD OFFENCE**

SIGNATURE OF SITE AGENT: _____ DATE: _____

SIGNATURE OF ECO/ESO: _____ DATE: _____

REMEMBER: TO BE FACTUAL WHEN DESCRIBING THE INCIDENT.

APPENDIX 12: COMPLAINTS REGISTER FORM

